

# HYDRAULIC CONTROL VALVES 水力控制閥



# S.K. VALVES

- DIAPHRAGM TYPE / 隔膜型 (2"~24")
- PISTON TYPE / 汽缸型 (14"~54")
- TUBELESS TYPE / 無配管型 (2"~10")



## PRINCIPLE OF MOVEMENT / 水力作動原理

Hydraulic Control Valve is operated hydraulically, designed to move by driving pressure difference between upside chamber and downside chamber which are caused by diaphragm or piston in valve. The diaphragm or piston divides the actuator into two distinct pressure chambers, and the control system list are also including disc, cock, tube, spring, needle valve and pilot valve.

Whenever the upside diaphragm chamber exceeds to the downside chamber in force ( caused by pipeline pressure ), the disc is enforced to close. Otherwise the disc is opened by pressure of downside chamber, pipeline system maintainers are able to operate the valve by driving the pilot valve and setting pressure balance of both pressure chambers, which could make the valve to be used in a wide range of applications.

水力型控制閥主要是藉由隔膜或活塞所形成的壓力室、閥盤、控制管路、針閥、響導閥所建構成的水力動態平衡系統，以達到設計之控制目的。

當壓力室所形成之推力大於管線動水對閥盤的推力則閥盤關閉；當壓力室所形成之推力小於管線動水對閥盤的推力則閥盤開啓；當壓力室所形成之推力等於管線動水對閥盤的推力則閥盤處於平衡的浮動調節狀態，而此平衡位置操作人員可藉由響導閥設定。

### DIAPHRAGM TYPE / 隔膜型

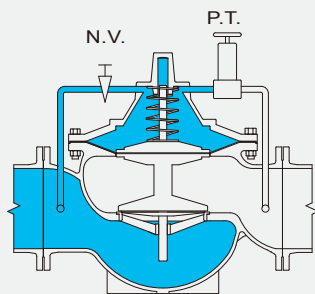

Disc Closing / 閥盤全關

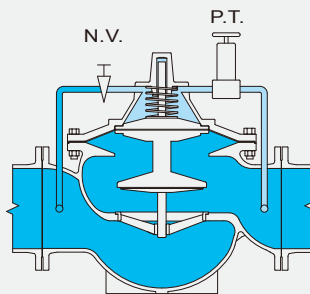

Disc Opening / 閥盤全開

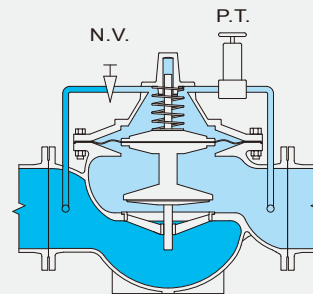

Disc Regulating / 閥盤浮動調節

### PISTON TYPE / 汽缸型

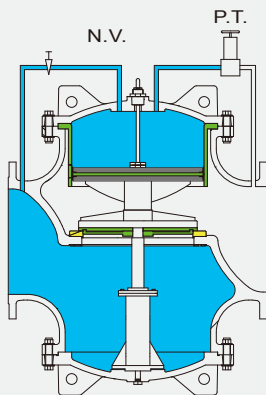

Disc Closing / 閥盤全關

### TUBELESS TYPE / 無配管型

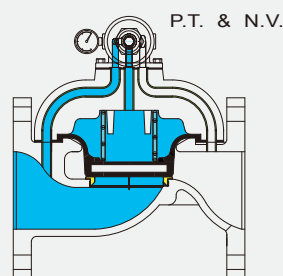

Disc Closing / 閥盤全關

N.V. : Needle Valve / 針閥  
P.T. : Pilot Valve / 響導閥

## APPLICATIONS / 應用範圍

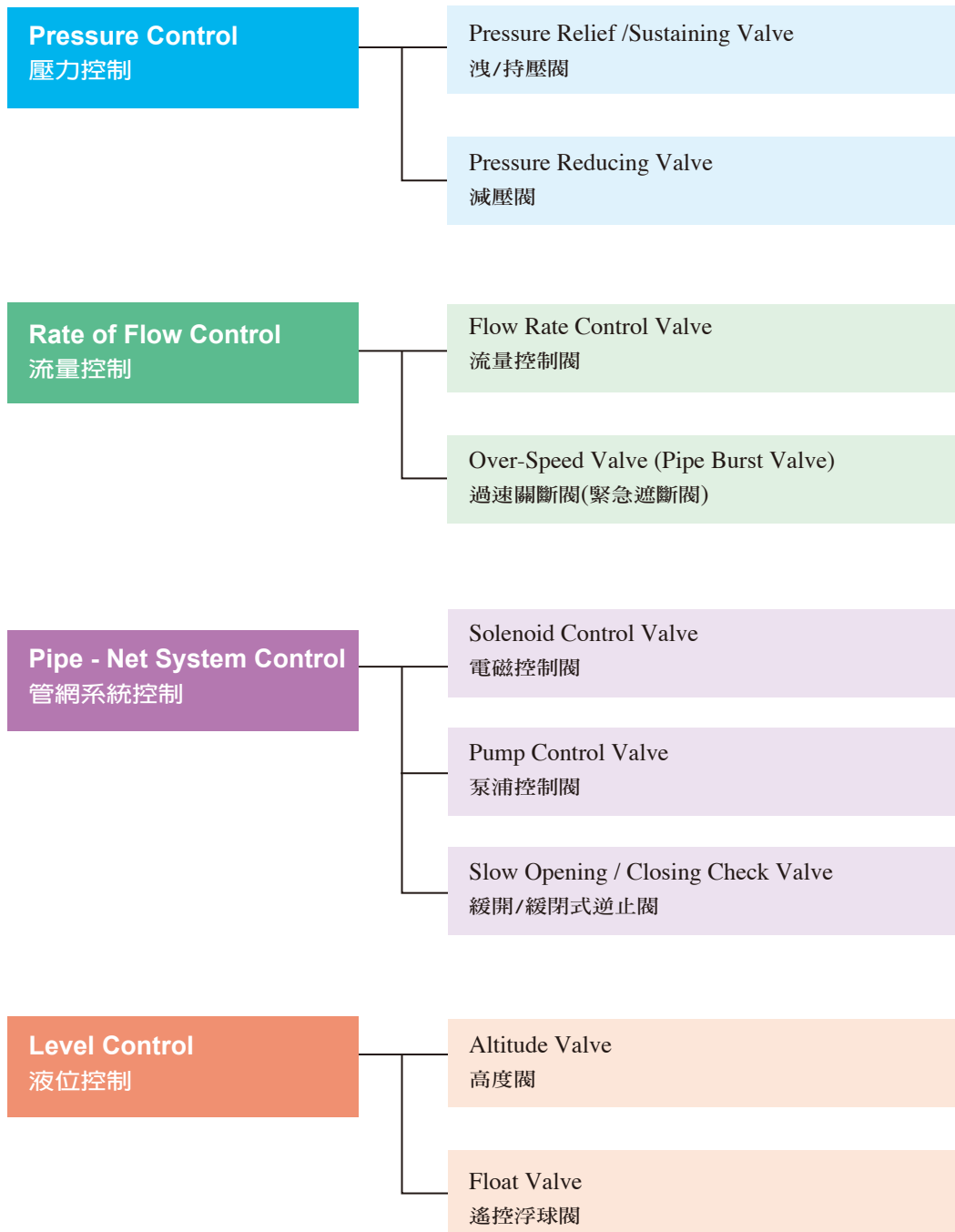

The combination designs of several functions are available. For instance pressure sustaining & reducing valve, pump control & pressure sustaining valve , level control & electrical remote....etc. If you need any special function, please contact us.

我們能提供兼具數個功能的設計，例如持壓兼減壓閥、泵浦控制閥附持壓功能、液位控制閥附遠端控制功能...等，如果您需要其它特殊的供能設計，請聯絡我們。



## PRESSURE CONTROL SERIES

### 壓力控制閥系列



#### GBD-RL SERIES

##### PRESSURE RELIEF/SUSTAINING VALVE 洩/持壓閥

The valve works for controlling pressure of upstream of pipeline. Preventing inlet pressure of valve higher than user's preset value. Whenever inlet pressure of valve exceeds user's preset pressure, valve will be opened fast to prevent inlet pressure over allowable pressure. Oppositely, valve will be closed slowly when inlet pressure of valve is lower than preset pressure. (Relief function)

In the other way, it could prevent upstream main transmission pipeline still supply downstream minor pipeline when the pressure of main transmission pipeline is lower than the lowest delivery pressure. (Sustaining function)

此型閥主要控制閥前端管線壓力，防止閥入口端壓力高於使用者的設定壓力。當閥入口端壓力高於設定壓力時，主閥快速開啓並維持調節狀態；當閥入口端壓力低於設定壓力時，主閥自動關閉，因此可確保閥入口端壓力於容許壓力範圍之內 (洩壓功能)。

除此之外，亦可用於防止上游主要輸水管線在低於基本送水壓力時，仍供給下游次要配水管線(持壓功能)。



#### GBD-RD SERIES

##### PRESSURE REDUCING VALVE 減壓閥

The valve works for controlling pressure of downstream of pipeline. Maintaining a constant outlet pressure of valve at user's preset value. Regardless of inlet pressure of valve or rate of flow of pipeline changing, the valve will be modulated to maintain a constant outlet pressure of valve at user's preset pressure automatically to prevent outlet pressure over allowable pressure.

此型閥主要控制閥後端管線壓力，維持穩定的閥出口端壓力於使用者設定壓力之內。無論閥入口端壓力變化或閥出口端管線用水量多寡，主閥自動增加或減少開度並維持調節狀態，以維持閥出口端供水壓力穩定，並防止閥出口端供水壓力超過容許範圍。



## RATE OF FLOW CONTROL SERIES

### 流量控制閥系列



#### **GBD-FW SERIES**

##### **FLOW RATE CONTROL VALVES 流量控制閥**

Maintains a constant rate of flow of pipeline at user's preset value. Regardless of inlet/outlet pressure of valve changing, the valve will be modulated to maintain a constant rate of flow at user's preset range automatically to prevent supply to over allowable rate of flow.

維持管線的流量於使用者設定的範圍之內。無論管線壓力如何變化，主閥閥盤自動增加或減少開度並維持調節狀態，以維持管線供水量穩定，並防止下游供水量超過容許範圍。

#### **BBF-EE(ME) SERIES**

##### **PIPE BURST CONTROL VALVES 緊急遮斷閥**

The valve will be shut off automatically when rate of flow of pipeline exceed user's preset value. Whenever the valve will be closed fast to reduce waste when rate of flow of pipeline is over user's preset value suddenly on downstream pipeline burst. And user can reset valve when pipeline will supply again.

當管線的流量高於使用者的設定流量時強制關閥。當管線流量因破管突然高於設定流量時，主閥能快速關閉以減少漏水浪費。當欲恢復通水時，只要重新設定即可。



## PIPE - NET SYSTEM CONTROL SERIES

### 管網系統控制閥系列



### GBD-SP SERIES VALVES

#### PUMP CONTROL VALVES 泵浦控制閥

The valve is installed on the discharge side of pump to prevent starting and stopping surges. The valve will be opened gradually when pump start up, and the valve will be closed slowly before pump shutdown, and the speed of opening and closing of valve are adjustable. When power failure occurred, the valve can immediately close to prevent return flow to damage pump. Therefore the valve could minimize surge, slam, and water hammer of pipeline to protect pump better than any check valves.

裝設於泵浦出口端以配合泵浦作動。當泵浦起動時主閥閥盤依設定自動緩慢開啓，當泵浦欲停機時主閥閥盤可先行緩速關閉，再停止泵浦運轉，且各行程速度可依需要調整，此外當遇電力中斷時能自動迅速關閉防止管線中的水逆流，因此可減少管線的突壓、水擊及水錘現象，增加泵浦的使用壽命。



### **GBD-SD(GBD-SC) SERIES**

#### **ELECTRICAL REMOTE VALVES 電磁控制閥**

The valve can be controlled by electrical signal. Both normally open (N.O.) type and normally close (N.C.) type are available, and the speed of opening and closing of valve are adjustable. Therefore users can control the process in accordance with electrical signal such as various pressure or flow rate.

以電子訊號來控制主閥的啓閉，有常開型及常閉型二種型式，且啓閉速度可依需要調整，因此可配合各種壓力或流量訊號作程序控制。



### **GBD-CV SERIES**

#### **SLOW OPENING/CLOSING CHECK VALVES**

##### **緩開/緩閉式逆止閥**

The valve is installed on the discharge side of pump or separate pipeline to prevent return flow. The speed of opening and closing of valve are adjustable. Therefore the valve could be applied widely in prevent return flow better than any check valves.

裝設於泵浦出口端或配水管線中，當作一緩閉之逆止閥，且啓閉速度可依需要調整，因此可減少管線的水擊及水錘現象。



## LIQUID LEVEL CONTROL SERIES

### 液位控制閥系列



#### GBD-FL SERIES

##### FLOAT VALVES 遙控浮球閥

The valve be installed at inlet of a water tank. Adjusting water level in predetermined rang to prevent the water overflow from reservoir or tank. Whenever water level lower than the shut-off location of float, valve will be opened for refilling reservoir or tank, and valve will be closed when water level reach to the shut-off location of float to prevent overflow.

此型閥主要配置於蓄水池上方或下方之進水管上，控制蓄水池水位於浮球設定的範圍之內以防止蓄水池溢流。當水池水位低於浮球裝設水位時主閥開啓補充水量；當水位達到浮球裝設水位時，主閥關閉停止進水，因此可防止蓄水池的水溢流。



#### GBD-AL SERIES

##### ALTITUDE VALVES 高度閥

The valve be installed at inlet of a water tank. Adjusting water level in predetermined rang to prevent the water overflow from reservoir or tank. Whenever water level lower than user predetermined level, valve will be opened for refilling reservoir or tank, and valve will be closed when water level reach to user predetermined level to prevent overflow. If two-way function is required, valve could be opened to return water from reservoir or tank when inlet pressure of valve is lower than level head.

此型閥主要配置於蓄水池下方進水管上，控制蓄水池水位於設定的範圍之內以防止蓄水池溢流。當水池水位低於設定水位時主閥開啓補充水量；當水位達到設定之高水位時主閥關閉停止進水，因此可防止蓄水池的水溢流。如果雙向流功能被指定時，當閥進口端水壓低於蓄水池水頭時，水能從蓄水池流回配水管中。



# MATERIAL & DIMENSION 材質與尺寸



## TUBELESS SERIES

### 無配管型控制閥系列

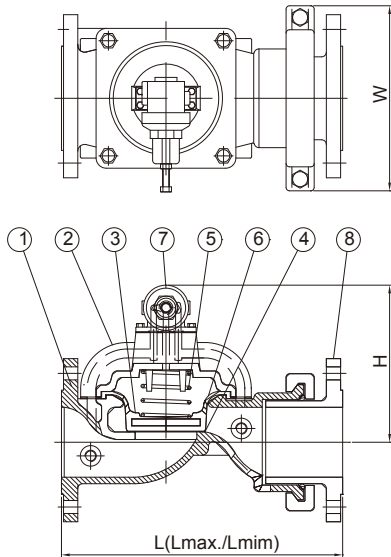

零件材質表

NO	PARTS 零件	MATERIAL 材質
1	Body 閥體	Ductile Cast Iron 球墨鑄鐵
2	Cover 閥蓋	Ductile Cast Iron 球墨鑄鐵
3	Disc 閥盤	Ductile Cast Iron 球墨鑄鐵
4	Seat 閥座	Bronze 青銅
5	Spring 彈簧	Stainless steel 不鏽鋼
6	Diaphragm 隔膜	Nylon Reinforced Neoprene 尼龍強化橡膠
7	Pilot valve 嚮導閥	Bronze 青銅 Stainless steel 不鏽鋼彈簧
8	Flexible joint 伸縮管	Ductile Cast Iron 球墨鑄鐵

DIMENSIONS / 主閥尺寸

unit : mm

SIZE	2"	3"	4"	6"	8"	10"
DIM.	DN50	DN75	DN100	DN150	DN200	DN250
Lmin	265	340	390	435	605	800
L	275	350	400	450	620	820
Lmax	285	360	410	465	635	840
(Lmax-Lmin)	20	20	20	30	30	40
W (max.)	210	260	310	385	460	540
H (max.)	210	240	270	320	370	430

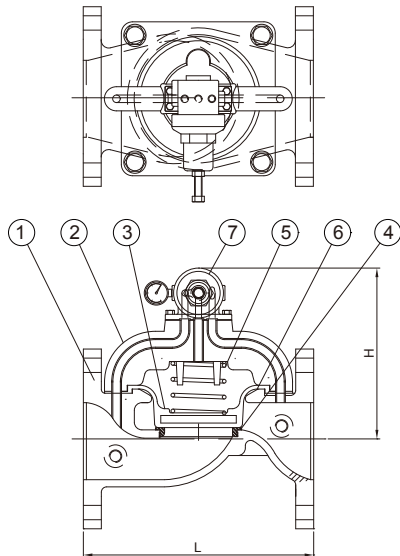

零件材質表

NO	PARTS 零件	MATERIAL 材質
1	Body 閥體	Ductile Cast Iron 球墨鑄鐵
2	Cover 閥蓋	Ductile Cast Iron 球墨鑄鐵
3	Disc 閥盤	Ductile Cast Iron 球墨鑄鐵
4	Seat 閥座	Bronze 青銅
5	Spring 彈簧	Stainless steel 不鏽鋼
6	Diaphragm 隔膜	Nylon Reinforced Neoprene 尼龍強化橡膠
7	Pilot valve 嚮導閥	Bronze 青銅 Stainless steel 不鏽鋼彈簧

DIMENSIONS / 主閥尺寸

unit : mm

SIZE	2"	3"	4"	6"	8"	10"
DIM.	DN50	DN75	DN100	DN150	DN200	DN250
L	203	285	360	455	585	790
H (max.)	210	240	270	320	370	430

# MATERIAL & DIMENSION 材質與尺寸



## GDB-X DIAPHRAGM TYPE

隔膜型

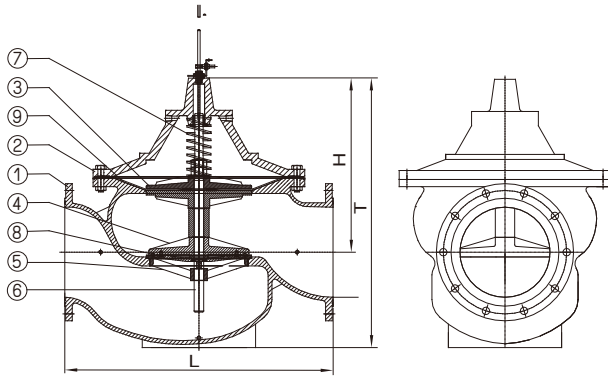

NO	PARTS 零件	MATERIAL 材質
01	Body 閥體	Ductile Cast Iron 球墨鑄鐵
02	Cover 閥蓋	Ductile Cast Iron 球墨鑄鐵
03	Diaphragm Plate 隔膜壓盤	Ductile Cast Iron 球墨鑄鐵
		Bronze 青銅
04	Disc 閥盤	Ductile Cast Iron 球墨鑄鐵
		Bronze 青銅
05	Seat 閥座	Stainless steel 不鏽鋼
		Bronze 青銅
06	Shaft 閥軸	Stainless steel 不鏽鋼
07	Spring 彈簧	Stainless steel 不鏽鋼
08	Seal 座封	NBR / EPDM / VITON 各式高級橡膠
09	Diaphragm 隔膜	Nylon Reinforced Neoprene 尼龍強化橡膠

DIMENSIONS / 主閥尺寸

unit : mm

SIZE	2"	3"	4"	6"	8"	10"	12"	14"	16"	18"	20"	24"
DIM.	DN50	DN80	DN100	DN150	DN200	DN250	DN300	DN350	DN400	DN450	DN500	DN600
L	203	285	360	455	585	790	900	962	962	1076	1076	1232
W	162	204	280	378	500	610	710	835	835	1035	1035	1232
H	230	280	360	500	645	765	910	1035	1035	1300	1300	1560
T	150	170	235	330	420	495	590	685	685	880	880	1050



## GBP-X PISTON TYPE

汽缸型

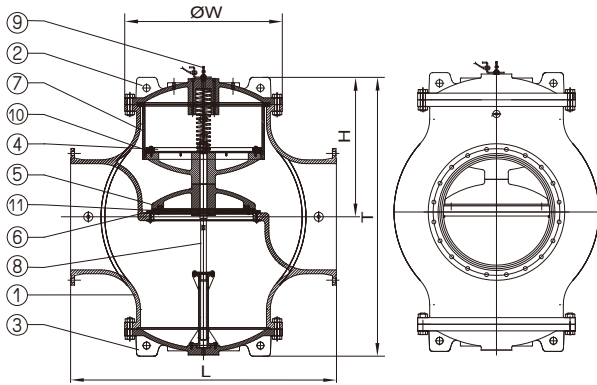

NO	PARTS 零件	MATERIAL 材質
01	Body 閥體	Ductile Cast Iron 球墨鑄鐵
02	Cover 閥蓋	Ductile Cast Iron 球墨鑄鐵
03	Bottom 底座	Ductile Cast Iron 球墨鑄鐵
04	Piston 活塞	Ductile Cast Iron 球墨鑄鐵
		Bronze 青銅
05	Disc 閥盤	Stainless steel 不鏽鋼
		Ductile Cast Iron 球墨鑄鐵
06	Seat 閥座	Bronze 青銅
		Stainless steel 不鏽鋼
07	Cylinder 汽缸	Stainless steel 不鏽鋼
08	Shaft 閥軸	Stainless steel 不鏽鋼
09	Indicator 開度指示桿	Stainless steel 不鏽鋼
10	Piston Seal 汽缸封環	NBR / EPDM / VITON 各式高級橡膠
11	Seal 座封	NBR / EPDM / VITON 各式高級橡膠

DIMENSIONS / 主閥尺寸

unit : mm

SIZE	14"	16"	18"	20"	24"	28"	30"	32"	36"	40"	Up to 54"
DIM.	DN350	DN400	DN450	DN500	DN600	DN700	DN750	DN800	DN900	DN1000	Up to DN1350
L	864	962	1076	1076	1232	1750	1750	1750	2250	2250	NOTE: Can be made as customer's requirement. 可依客戶需求製作。
W	820	820	950	950	1100	1350	1350	1350	1592	1592	
T	1150	1150	1320	1320	1450	1860	1860	1860	1735	1735	
H	575	575	660	660	725	930	930	930	1180	1180	

## SPECIFICATIONS 規格說明

Pressure Class & Flange / 壓力等級 & 法蘭規格				Fluid / 適用流體
Standard 規格	Class 等級	Operating Pressure 工作壓力	Flow Rate Range 流速範圍	Clean Water 清水
ANSI	125	10 - 175 psi	Normal Service 常態流速 1.5 - 15 ft/sec 0.5 - 5 m/sec	Fluid Temperature Range / 流體溫度
	250	10 - 300 psi		0 - 80 ° C / 32 - 176 ° F (Liquid 液態)
ISO / DIN / BS	PN10	0.7 - 10 kgf/cm <sup>2</sup>	Intermittent Service 容許瞬間流速 25 ft/sec 8 m/sec	Testing Pressure / 測試壓力
	PN16	0.7 - 16 kgf/cm <sup>2</sup>		According to ISO 5208 (Rate 3) SEAT / 閥座 : 1.1 × Max. Operating Pressure BODY / 閥體 : 1.5 × Max. Operating Pressure
JIS / CNS	7.5 K	0.7 - 7.5 kgf/cm <sup>2</sup>		
	10.0 K	0.7 - 10 kgf/cm <sup>2</sup>		
	16.0 K	0.7 - 16 kgf/cm <sup>2</sup>		

### AREA-A 區域A

The cavitation will occur to accelerate wearing.  
在此區域氣蝕將可能產生氣蝕現象，加速閥件磨損。

### AREA-B 區域B

Normal working rang.  
此區域為正常工作範圍。

### AREA-C 區域C

Not applicable.  
此區域控制閥不適用。

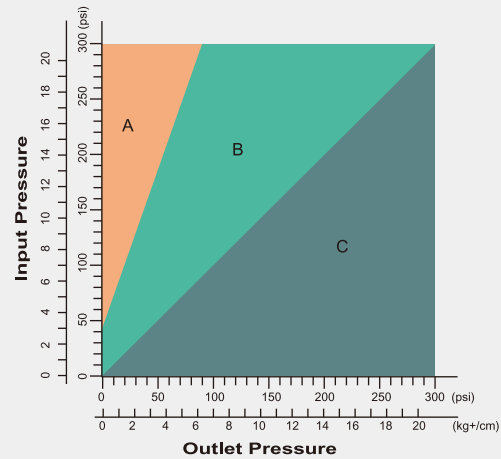

## OPTIONAL / 其它選配

### ● Standard Double-Chamber Main Valves

#### 雙密閉壓力室型主閥

The standard Double-Chamber Main Valve provides constant and accurate control.

雙密閉壓力室型主閥可提供較穩定且精準的控制

### ● Angle Pattern Main Valves / 角型主閥

Angle Pattern Main Valve provides different installation selection.

### ● V-Port Plug Module / V-Port 閥塞模組

The V-Port Plug Module can be used for low flow or high differential pressures situation.

V-Port閥塞模組適用於小流量或高壓差的控制場合

### ● Multi-Port Sleeve Module/ 多噴口套筒模組

The Multi-Port Sleeve Module can be used for provides a superior and accurate control, when extreme pressure and flow conditions .

多噴孔套筒模組能提供較優越及精準的控制，尤其在極端的壓力及流量之下。

TUBELESS TYPE / 無配管型

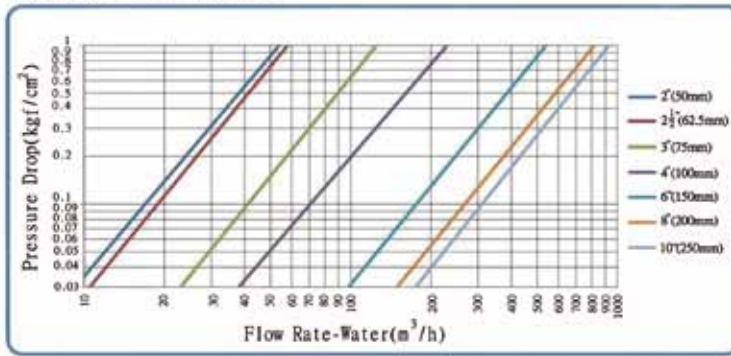

DIAPHRAGM TYPE / 隔膜型

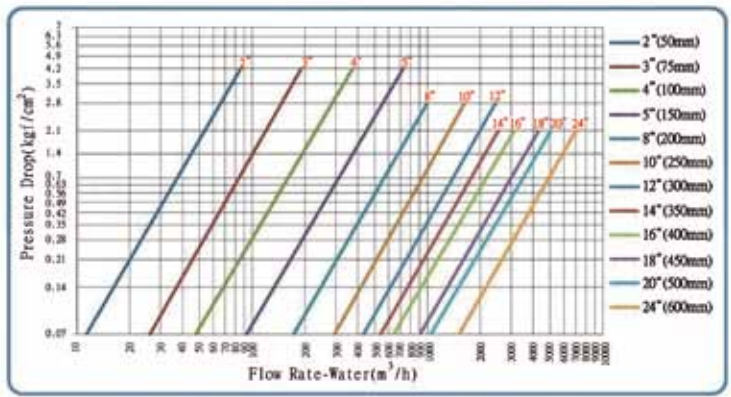

PISTON TYPE / 汽缸型

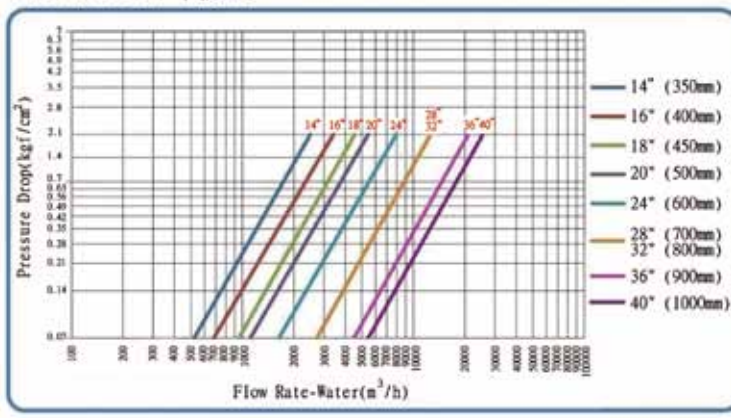

**SKYE KUANG VALVES MFG CO., LTD.**  
**叶光閥業股份有限公司**  
**EN IN ENTERPRISE CO., LTD**  
**恩盈企業股份有限公司**

屏東縣萬巒鄉佳興路83號 郵遞區號:923  
 No. 83, Chia Hsing Rd., Wanluan, Pingtung 923,  
 Taiwan R.O.C

Tel: +886-8-7833834 Fax: +886-8-7833734

E-mail: marketing@skvalves.com.tw

Http: //www.skvalves.com.tw

