



Since 1966



# SK VALVES

## BALL TYPE AUTOMATIC CONTROL VALVES

### 球塞控制閥



- GEAR TYPE 渦齒式 (8"~40")
- BEAM TYPE 曲柄式 (8"~104")

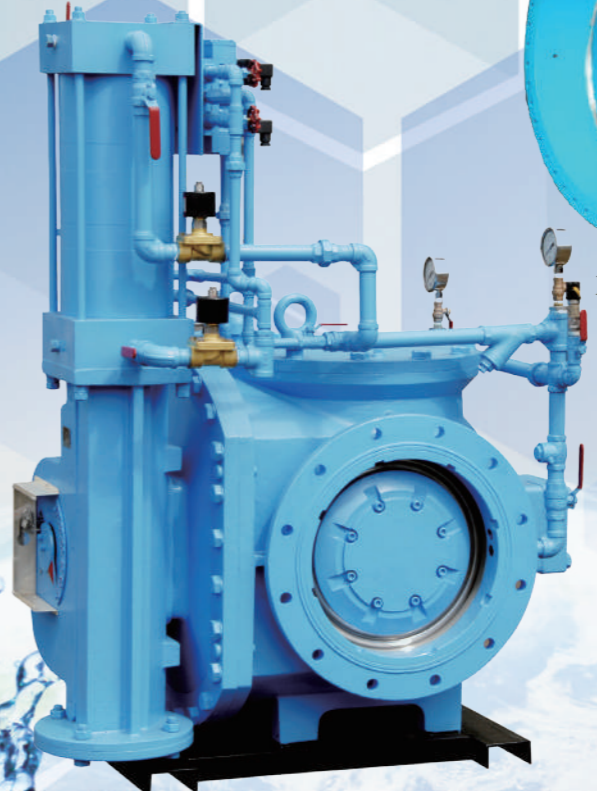

叶光閥業股份有限公司 SHYE KUANG VALVES MFG CO.,LTD.  
 恩盈企業股份有限公司 EN IN ENTERPRISE CO.,LTD.

■ 總公司 Headquarter  
 923屏東縣萬巒鄉佳興路83號 No. 83, Chia-Hsing Rd., Wan-Luan, Pingtung 923, Taiwan R.O.C.  
 TEL : +886-8-783-3834 FAX : +886-8-783-3734 Skype: skvalve.andrew  
 E-mail: international@skvalves.com.tw

■ 北區辦公室 North Taiwan Office  
 241新北市三重區環河北路三段270號1樓  
 No. 270, Sec. 3, Huanhe N. Rd., Sanchong Dist., New Taipei City 241076, Taiwan R.O.C.  
 TEL : +886-2-2988-4657 FAX : +886-2-2988-4657



www.skvalves.com.tw

■ 本公司對型錄所列之材質與尺寸保留認為必要時作修改之權利，或依客戶需求設計，實際尺寸及材質仍以客戶訂購時所提供之圖說為準。  
 SK Valves reserves the right to modify the materials or/and dimensions of the products as provided hereunder from time to time if necessary, or in accordance with the request of clients. The actual dimensions or/and material used are subject to the customer's request after placing the order.

# PRODUCT DESCRIPTION 產品概說

Ball valves have a more efficient shut-off capability compared with butterfly valves. Its water-sealing function and life service are better than butterfly valves when served in larger pipelines and under higher-pressure working conditions. It is designed to work in proportional and on-off controls. As the graph illustrated below, a linear relation can be observed from 0 to 60 percent stroke, which indicates the proportional control interval. Moreover, zero head loss can be reached when it is fully open. These traits made ball valves validate to act as a flow regulator when connected to pump station pipelines and a shut-off valve for interconnecting pipelines.

球塞型控制閥比較於蝶閥有更有效的關斷功能，且比閘閥更適合作大口徑使用，球塞型控制閥尤其在高壓環境下，球塞型控制閥止水性更佳且使用壽命更長。

球塞型控制閥在行程60%以內可作等比例控制控制，且當開度到達100%的時候，可以達到全流域流量而無水頭損失，因此在聯通管路中常作為重要的關斷控制閥，在加壓站中亦可作為泵浦控制閥。

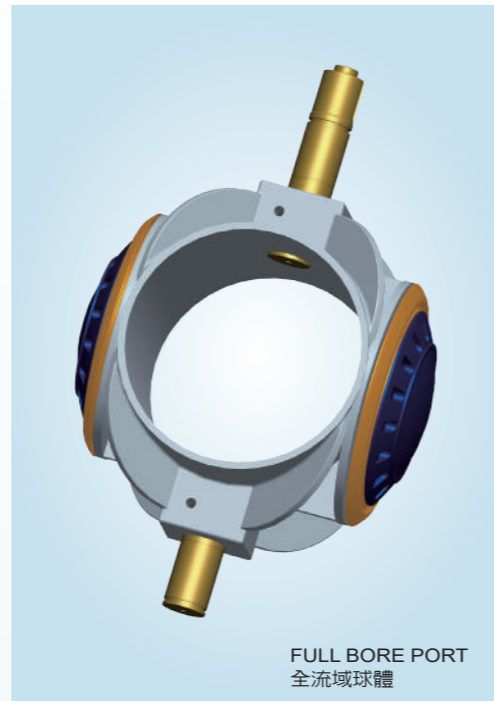

閥行程與流量係數比例圖  
STROKE & Cv %

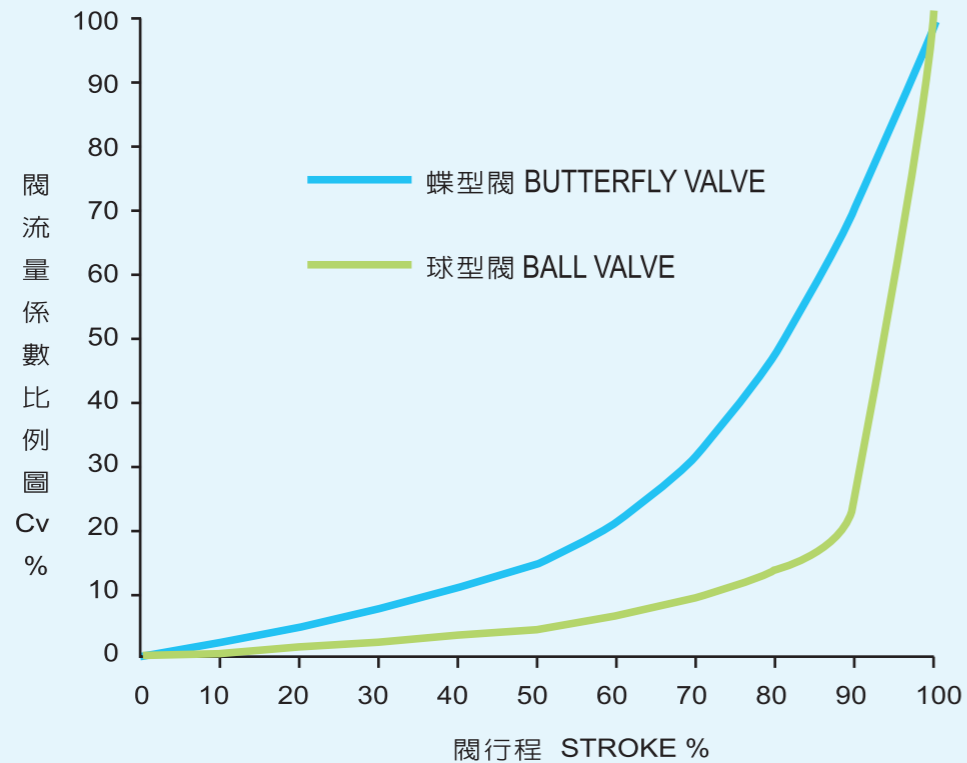

## THE MODEL OF PRODUCT 產品功能概要

Control valve type 控制閥型式	Control system 控制系統	Main function description 主要功能說明
BVE-A level control valve 液位控制閥	<ul style="list-style-type: none"> <li>Actuator(optional) water cylinder, oil cylinder, pneumatic w/oil, motor actuator</li> <li>Site control box</li> <li>Control system(optional) Leve sensor module Solenoid module PLC</li> <li>操作機(選配) 水壓缸/油壓缸/氣油壓缸/電動操作機</li> <li>現場控制箱</li> <li>控制系統(選配) 液位傳訊模組/電磁閥模組/ 可程式控制器</li> </ul>	<p>Installed on the inlet pipeline of the reservoir to regulate water inflow. BVE-A controls the flow rate to fill thereservoir at low water levels and stops the flow when the water level reaches high levels.</p> <p>裝設於蓄水槽進水管上，可自動控制蓄水槽液位，當液位處於低水位狀態則主閥開啓補充進水，當液位處於高水位狀態則主閥關閉停止進水，液位控制方式可依顧客需要設計。</p>
BVE-P Pump Control Valve 泵浦控制閥	<ul style="list-style-type: none"> <li>Actuator (optional) water cylinder、oil cylinder pneumatic w/oil、motor actuator</li> <li>Site control box</li> <li>Control system (optional) Pressure sensor module Solenoid module PLC</li> <li>操作機(選配) 水壓缸/油壓缸/氣油壓缸/電動操作機</li> <li>現場控制箱</li> <li>程序控制器(選配) 壓力傳訊模組 電磁閥模組 可程式控制器</li> </ul>	<p>Installed on the pump outlet to act as a shut-off valve. When the pump starts, the BVE-P opens the valve slowly, avoiding the pressure surge. When closing the pump, close the ball valve to 85% - 90% in advance to avoid any damage caused by the water hammer and backflow. In case of a power outage,BVE-P can rapidly close the valve for up to 80% of the stroke, and the rest would be done slowly.</p> <p>裝設於泵浦出口端兼具關斷及緩閉阻斷逆流的功能，當泵浦啓動時主閥緩速開啓，避免泵浦啓動瞬間所造成的突壓，當泵浦欲停機時主閥可先行關閉85%-90%，再停止泵浦運轉，可避免水錘造成的任何損壞及防止管線中的水逆流。若遇電力中斷時主閥亦可迅速關閉約80%，其餘行程再緩速關閉。必要時亦可配合客戶需要作更smart的控制。</p>
BVH Process Control Valve 關斷型程式控制閥	<ul style="list-style-type: none"> <li>Actuator(optional) water cylinder, oil cylinder, pneumatic w/oil, motor actuator</li> <li>Site control box</li> <li>Seneor(optional) Flow meter Pressure seneor Manual model</li> <li>操作機(選配) 水壓缸/油壓缸/氣油壓缸/電動操作機</li> <li>現場控制箱</li> <li>感測器： 流量計/壓力傳訊器/ 機械式手動操作模組</li> </ul>	<p>In water distribution system, BVH operates its programmed control according to the sensors' feedback (pressure, flow rate ...etc.).</p> <p>裝設於送配水管線上，可配合各種壓力或流量之回饋訊號作程序控制。</p>

## DESIGN FEATURE 設計特點

Ball valve total movement is accomplished in a rotation of 90 degrees. In the open position, the ball's full bore has the same dimension as the valves' two ends, which makes the head loss almost close to zero.

球塞型控制閥為一種90°啟閉的閥，當閥門全開時球體開口與管線口徑一致，幾乎達到“0”水頭損失與同口徑直管相同。

Upon customer request, we provide both single-seat and double-seat designs. The single-seat design has a directional preference for water-sealing function, unlike the double-seat design.

依客戶需求可分為單閥座型及雙閥座型二種。單閥座型的止漏設計具有方向性；雙閥座型的止漏設計沒有方向性。

The valve seat's floating design reduces the required working torque to open the valve. When the valve is in the closed position, the floating seat can adjust its position with the body seat, and the water pressure within the valve can push the floating seat to seal tighter.

球體閥座採用金屬-金屬、浮動球面設計，能夠有效降低開啓及關閉時的操作扭矩及自動修正入座位置。

Floating sphericity seat design 浮動球座設計

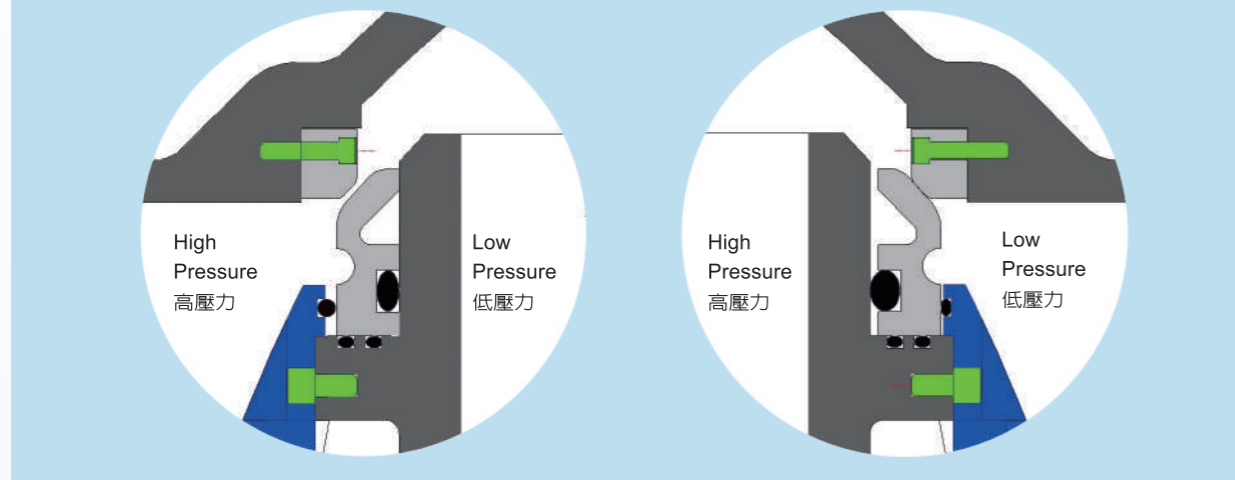

Moreover, triple eccentric design is further deployed to improve the life service and reduce the friction between the seats.

大口徑球塞型控制閥更採用三偏設計，當球體開啓時球體閥座能快速脫離本體閥座，減少閥座-閥座間的摩擦，除能有效降低開啓及關閉扭力，更能延長使用壽命。

Two options for the driven modules are BEAM TYPE and WORM GEAR TYPE. The BEAM TYPE-driven box is a linkage mechanism that converts rotational motion into linear motion, automatically generating a buffering effect when opened or closed to approximately the first 15% of the total stroke, which suits well for Ball valves' working scenario. When the valve is closing, the 15% buffering effect can reduce the impact of the water hammer on the valve; while the valve is opening, this buffering effect can reduce the peak working current of the actuator, especially for the more significant size of the valve.

球塞型控制閥之驅動機構有曲柄式驅動箱及渦齒輪減速箱二種可選用。

曲柄式驅動箱是一種將旋轉運動轉變為直線運動的連桿機構，可以在開啓或關閉約15%的開度時自動產生緩衝效果。此特性於泵浦控制閥時有極佳的適用性，當抽水機啓動時，此15%行程的緩慢開啓，可消除電動操作機啓動瞬間電流增大的情形，而當抽水機停機時，此15%的緩慢關閉，可有效減少水錘產生，保護抽水機及管線的安全。另外其在閥開及關瞬間的高扭力輸出的特性適合搭配大口徑球塞型控制閥。

BEAM TYPE DRIVE MOVEMENT 曲柄式驅動機構作動原理

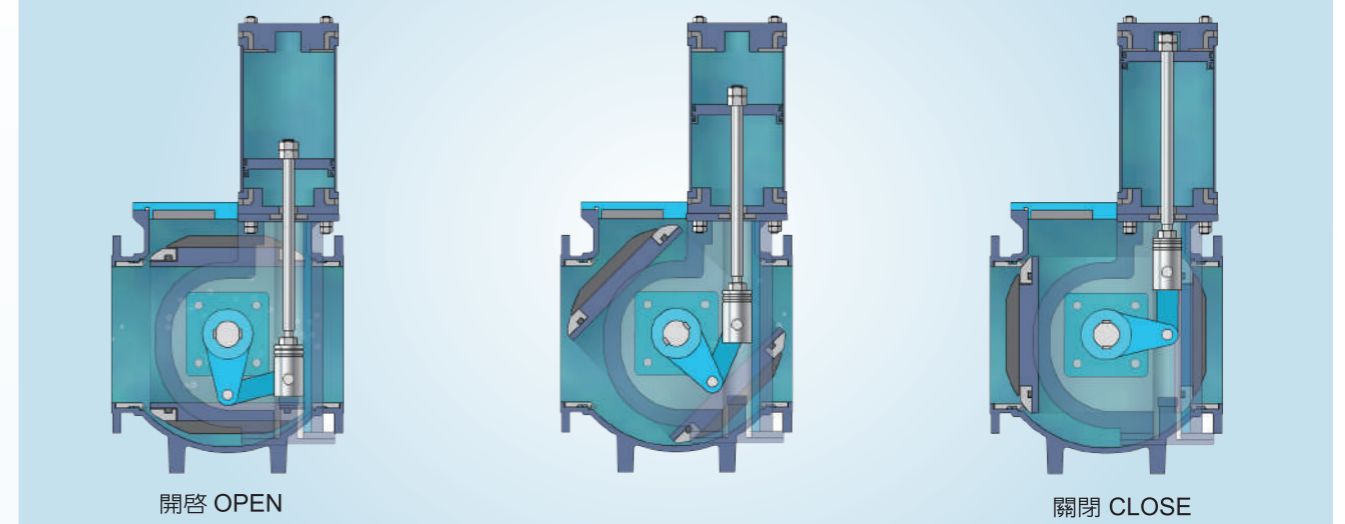

BEAM TYPE DRIVE STROKE & TORQUE CURVE

曲柄式驅動機構-行程&扭力曲線圖

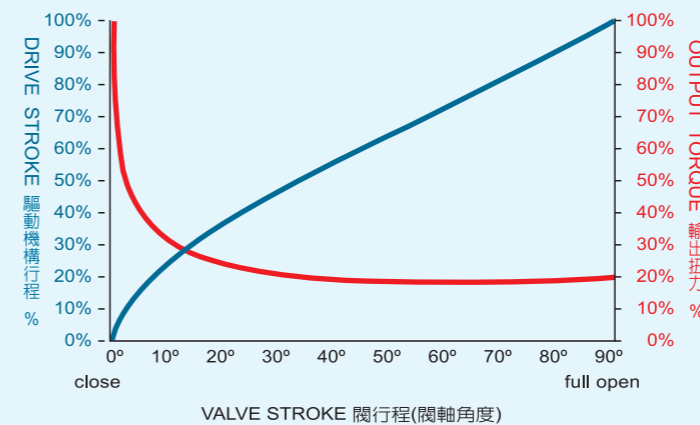

曲柄式 BEAM TYPE

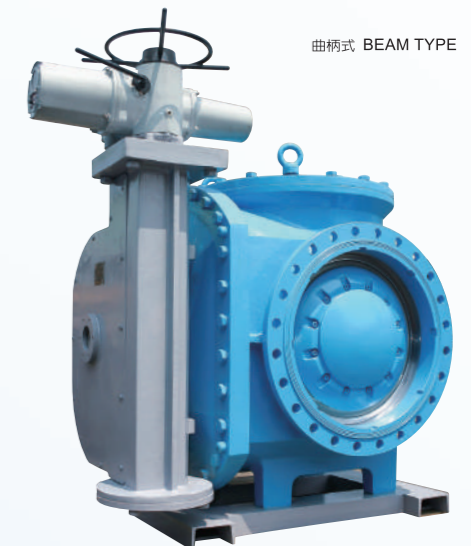

- The WORM GEAR TYPE driver can be used on BALL TYPE CONTROL VALVE, which is smaller than the size of DN1000.

渦齒輪減速箱較適合DN1000(40")口徑以下之球塞型控制閥。

BEAM & GEAR TYPE DRIVE STROKE CURVE

曲柄式&渦齒式 驅動機構行程曲線圖

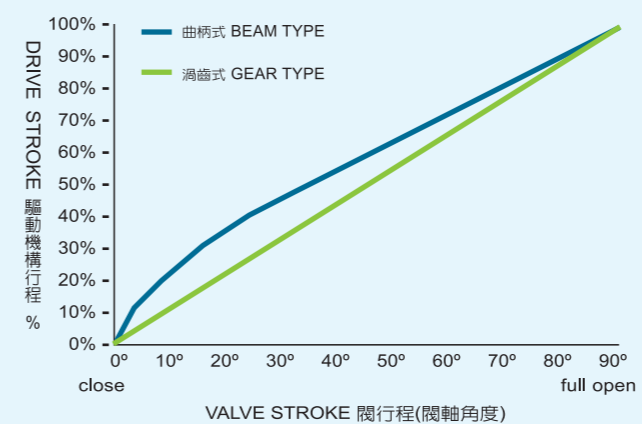

渦齒式 GEAR TYPE



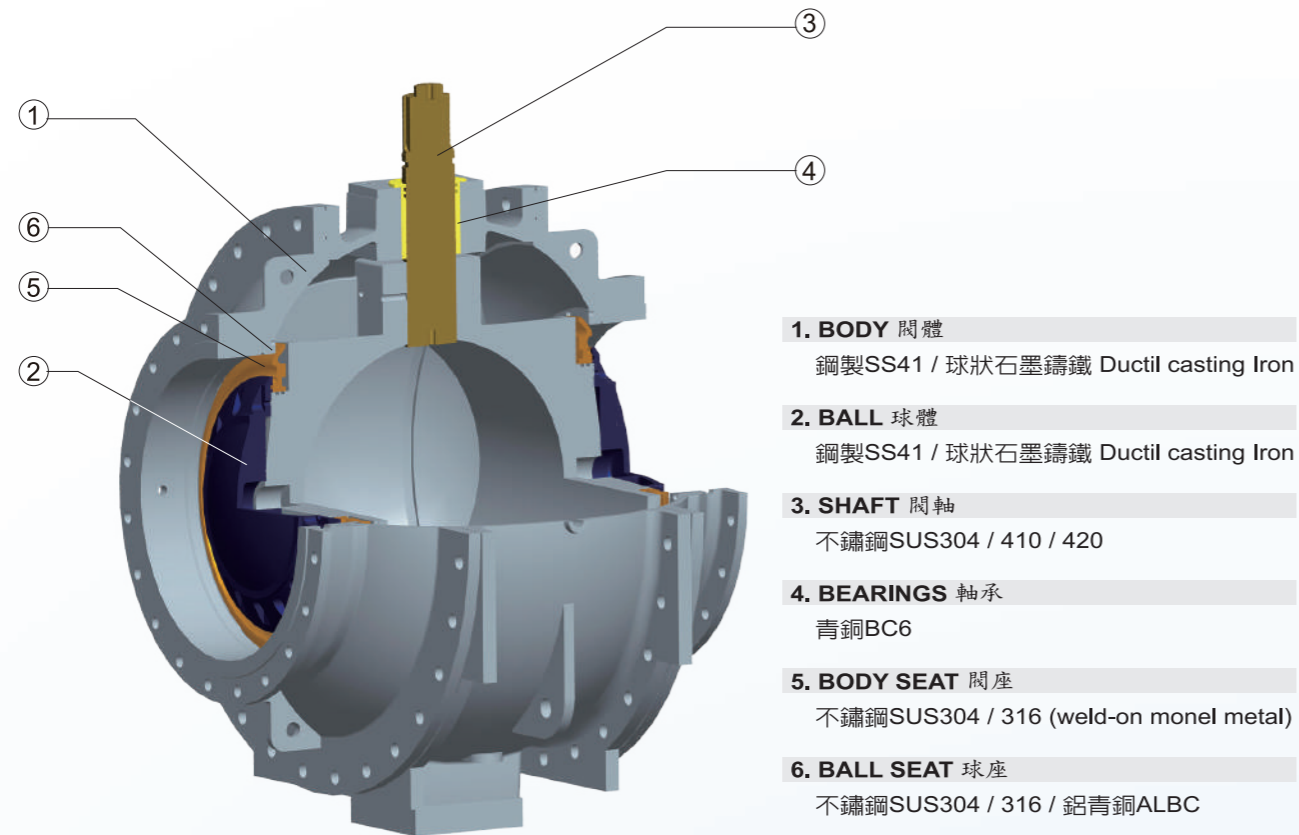

- 1. BODY 閥體**  
鋼製SS41 / 球狀石墨鑄鐵 Ductil casting Iron
- 2. BALL 球體**  
鋼製SS41 / 球狀石墨鑄鐵 Ductil casting Iron
- 3. SHAFT 閥軸**  
不鏽鋼SUS304 / 410 / 420
- 4. BEARINGS 軸承**  
青銅BC6
- 5. BODY SEAT 閥座**  
不鏽鋼SUS304 / 316 (weld-on monel metal)
- 6. BALL SEAT 球座**  
不鏽鋼SUS304 / 316 / 鋁青銅ALBC

EXPLODED VIEW 分解圖

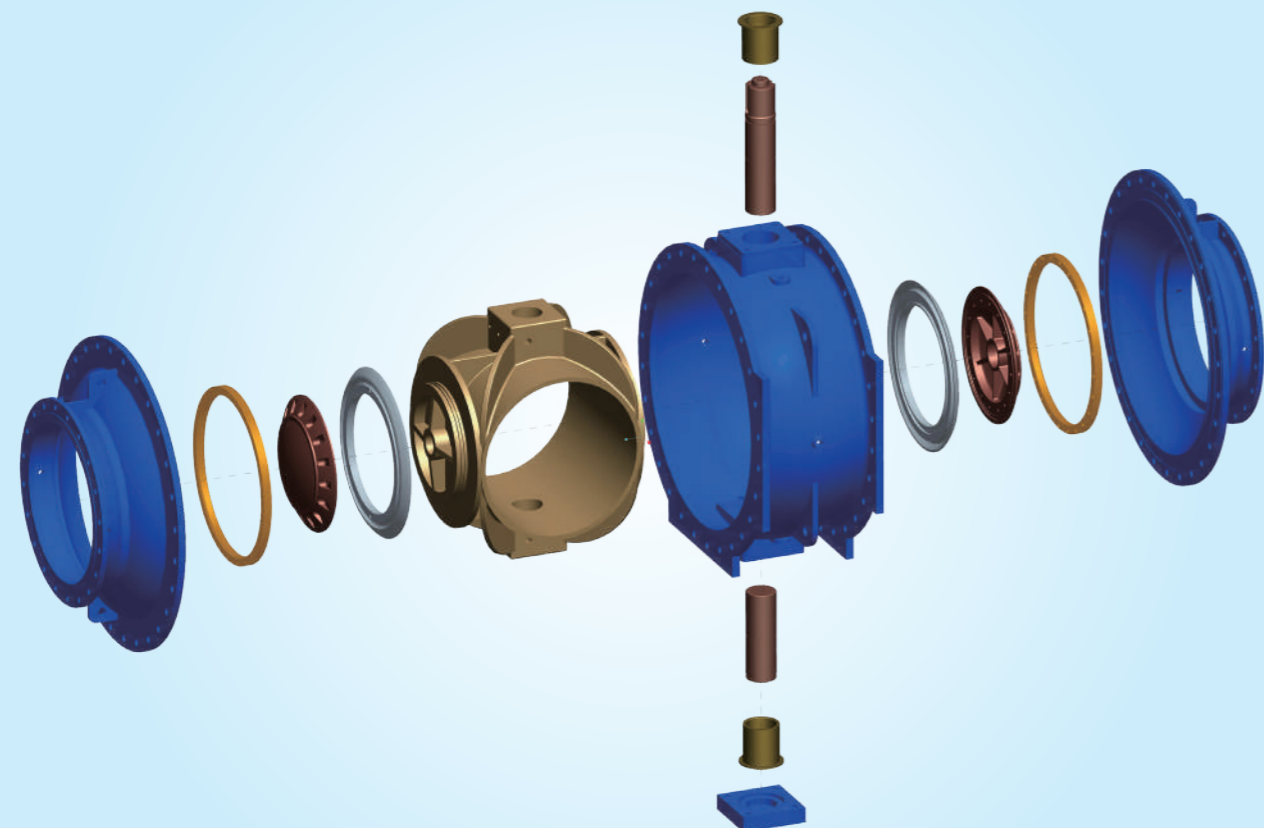

**VENTURI-TYPE WAY 文氏管施工法**

Using the Venturi tube construction method allows for installing smaller-diameter ball valve control valves on larger pipelines. For example, the head loss of a DN600 ball valve control valve is less than that of a DN750 butterfly valve, thus effectively reducing project costs.

使用文氏管施工法可在大管線上安裝較小口徑的球塞型控制閥，例如：DN600球塞型控制閥的水頭損失小於DN750的蝶閥，因此可有效降低工程成本

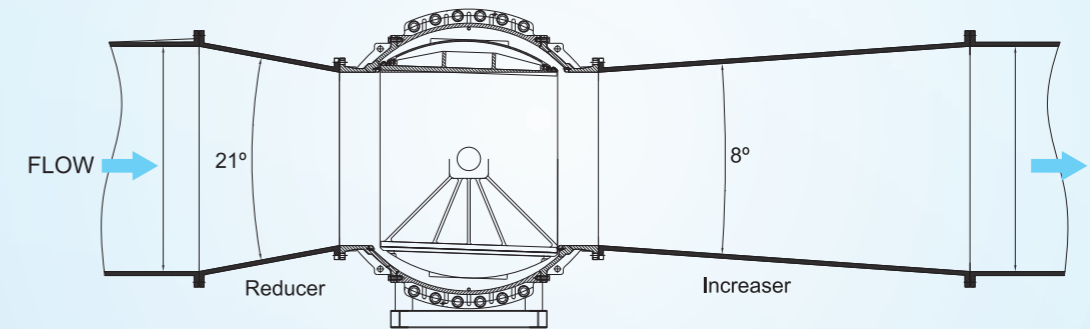

**SPECIFICATIONS 規範說明**

Pressure Class & Flange 壓力等級&法蘭規格		
Standard 規格	Class 等級	Pressure 工作壓力
ANSI	125	0 - 175 psi
	300	0 - 300 psi
ISO DIN BS	PN10	0 - 10 kgf/cm <sup>2</sup>
	PN16	0 - 16 kgf/cm <sup>2</sup>
JIS CNS	7.5 K	0 - 10 kgf/cm <sup>2</sup>
	10.0 K	0 - 10 kgf/cm <sup>2</sup>
	16.0 K	0 - 16 kgf/cm <sup>2</sup>

Fluid 適用流體 流體溫度
Clean Water / Raw Water 自來水、原水
Temperature Range 流體溫度
0 - 80 °C / 32 - 176 °F
Testing Pressure 測試壓力
According to ISO 5208(Rate 3) SEAT閥座: 1.1 x Max.Operating Pressure BODY閥體: 1.5 x Max.Operating Pressure

**OPTIONS 其他配件**

- **油壓動力單元**  
含驅動馬達、油壓泵浦、蓄壓器、油槽、控制箱
- **氣壓動力單元**  
含空壓機、蓄壓桶、控制箱
- **電動操作機**  
含驅動馬達、減速機、控制面板
- **Hydraulic power kit**  
Including motor、oil pump、pressure tank、oil tank control box
- **Pneumatic power kit**  
Including air compressor、pressure tank、control box
- **Motor actuator**  
Including motor actuator、gear box、control panel

