



Since 1966

SK VALVES

CHECK VALVES

逆止閥



Swing Type Check Valves ■
擺動式逆止閥 $\Phi 75\sim\Phi 1050\text{mm}$
(3" ~ 42")

Butterfly Type Check Valves ■
蝶式逆止閥 $\Phi 100\sim\Phi 2000\text{mm}$
(4" ~ 80")

Slant Type Check Valves ■
斜盤式逆止閥 $\Phi 150\sim\Phi 2000\text{mm}$
(6" ~ 80")

Rubber Flapper Swing Check Valves ■
橡膠閘瓣逆止閥 $\Phi 50\sim\Phi 1200\text{mm}$
(2" ~ 48")

Single Plate Type Check Valves ■
單瓣逆止閥 $\Phi 25\sim\Phi 600\text{mm}$
(1" ~ 24")

Dual Plate Type Check Valves ■
雙瓣逆止閥 $\Phi 50\sim\Phi 1000\text{mm}$
(2" ~ 40")

Ball Type Check Valves ■
球式逆止閥 $\Phi 50\sim\Phi 500\text{mm}$
(2" ~ 20")

Nozzle Type Check Valves ■
環狀噴流式逆止閥 $\Phi 75\sim\Phi 1000\text{mm}$
(3" ~ 40")

叶光閥業股份有限公司 SHYE KUANG VALVES MFG CO.,LTD.
恩盈企業股份有限公司 EN IN ENTERPRISE CO.,LTD.

■ 總公司 Headquarter
923屏東縣萬巒鄉佳興路83號 No. 83, Chia-Hsing Rd., Wan-Luan, Pingtung 923, Taiwan R.O.C.
TEL : +886-8-783-3834 FAX : +886-8-783-3734 Skype: skvalve.andrew
E-mail: international@skvalves.com.tw

■ 北區辦公室 North Taiwan Office
241新北市三重區環河北路三段270號1樓
No. 270, Sec. 3, Huanhe N. Rd., Sancong Dist., New Taipei City 241076, Taiwan R.O.C.
TEL : +886-2-2988-4657 FAX : +886-2-2988-4657



www.skvalves.com.tw

■ 本公司對型錄所列之材質與尺寸保留認為必要時作修改之權利，或依客戶需求設計，實際尺寸及材質仍以客戶訂購時所提供之圖說為準。

SK Valves reserves the right to modify the materials or/and dimensions of the products as provided hereunder from time to time if necessary, or in accordance with the request of clients. The actual dimensions or/and material used are subject to the customer's request after placing the order.

PRODUCT DESCRIPTION 產品概說

- The main function of check valves is to ensure the flow direction in the pipeline to be consistent.
逆止閥在管線中之主要功能為確保流體之單一流向
- There are 8 types of check valves available and suit for different circumstances.
逆止閥型式八大類型，提供不同環境配置安裝。
- The check valves are to prevent the reverse flow and the damages occurred by water hammer.
逆止閥功能在於防止水逆流及降低水錘所造成的管線損壞。

CHECK VALVES CLASSIFICATION 逆止閥特性分類表		
Type 產品型式	Fluid 適用流體 ○ Clean Water 清水 ○ Raw Water 原水 ● Waste Water 廢水 ※ Sewage 污水	Application 適合安裝方式 ← Horizontally 水平 ↑ Vertically 垂直安裝
Swing Type Check Valves 擺動式逆止閥	○、◎	←
Butterfly Type Check Valves 蝶式逆止閥	○、◎	←
Slant Type Check Valves 斜盤式逆止閥	○、◎	← ↑
Rubber Flapper Swing Check Valves 橡膠閘瓣式逆止閥	○、◎、●、※	← ↑
Single Plate Type Check Valves 單瓣逆止閥	○、◎	←
Dual Plate Type Check Valves 雙瓣逆止閥	○、◎	← ↑
Ball Type Check Valve 球式逆止閥	○、◎、●、※	← ↑
Nozzle Type Check Valves 環狀噴流式逆止閥	○	← ↑

FEATURES 特性

FEATURES 特性	Low head loss 低水頭損失	Resilient seat 彈性閘座	Metal seat 金屬閘座	Quickly shut off 快速關閉
Swing Type Check Valves 擺動式逆止閥		●		
Butterfly Type Check Valves 蝶式逆止閥			●	
Slant Type Check Valves 斜盤式逆止閥	●		●	
Rubber Flapper Swing Check Valves 橡膠閘瓣式逆止閥		●		
Single Plate Type Check Valves 單瓣逆止閥		●		
Dual Plate Type Check Valves 雙瓣逆止閥		●		
Ball Type Check Valve 球式逆止閥		●		
Nozzle Type Check Valves 環狀噴流式逆止閥	●		●	●

CHECK VALVES HEAD LOSS CURVES 逆止閥水頭損失曲線圖

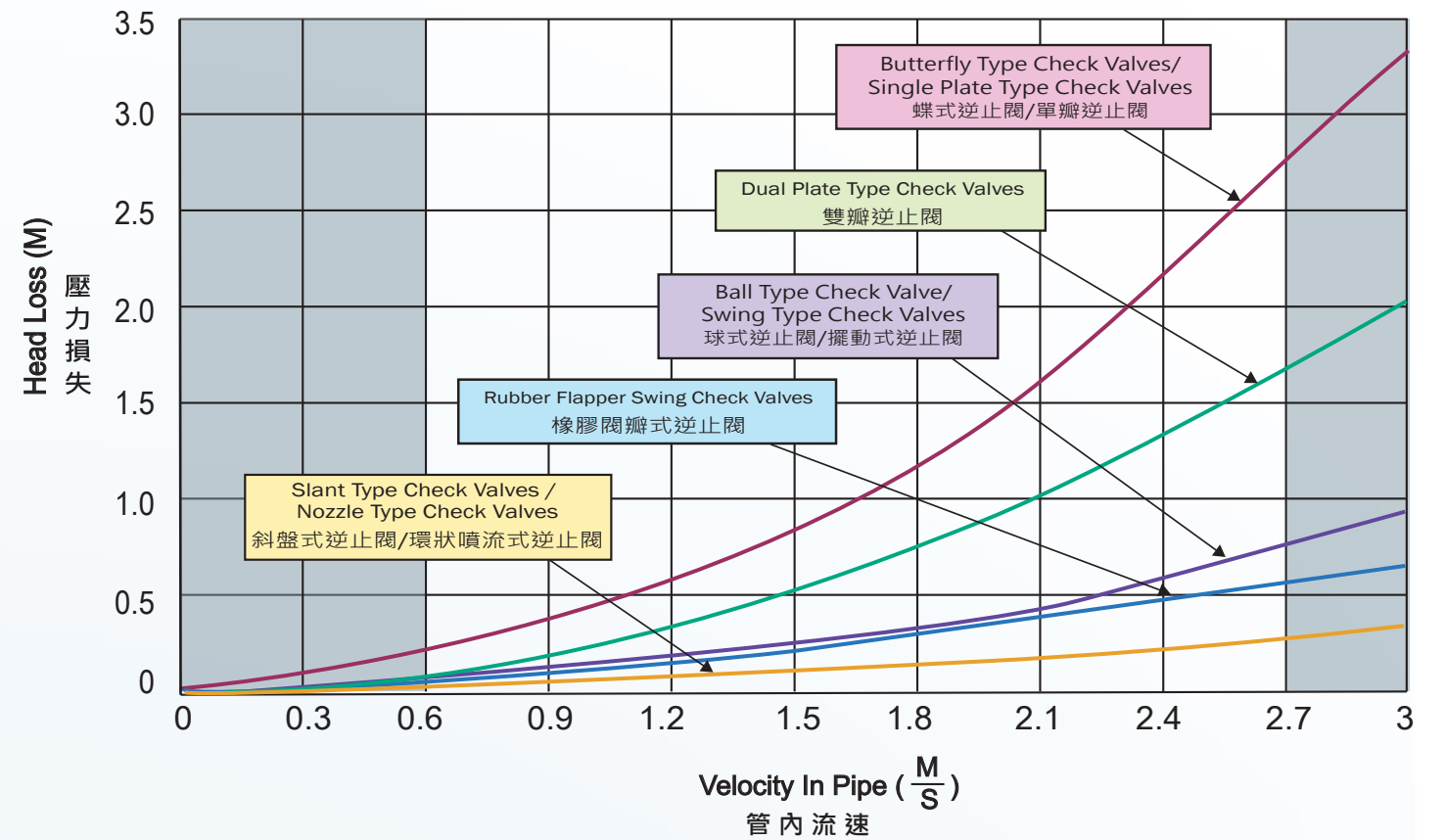

OPTIONAL 模組選配表

MODULE 模組	Counter Weight 重錘型	External Spring 外部彈簧型	Air Cushion 空氣緩衝型	Oil Cushion 油壓緩衝型	Push Stick 反沖洗推桿	External drive 外部控制裝置
Swing Type Check Valves 擺動式逆止閥	●	●	●	●		
Butterfly Type Check Valves 蝶式逆止閥	●			●		●
Slant Type Check Valves 斜盤式逆止閥	●			●		●
Rubber Flapper Swing Check Valves 橡膠閘瓣式逆止閥			●	●	●	
Single Plate Type Check Valves 單瓣逆止閥		●				
Dual Plate Type Check Valves 雙瓣逆止閥						
Ball Type Check Valve 球式逆止閥						
Nozzle Type Check Valves 環狀噴流式逆止閥						

SWING TYPE CHECK VALVES 擺動式逆止閥 $\Phi 75\sim\Phi 1050\text{mm}$ (3" ~ 42")

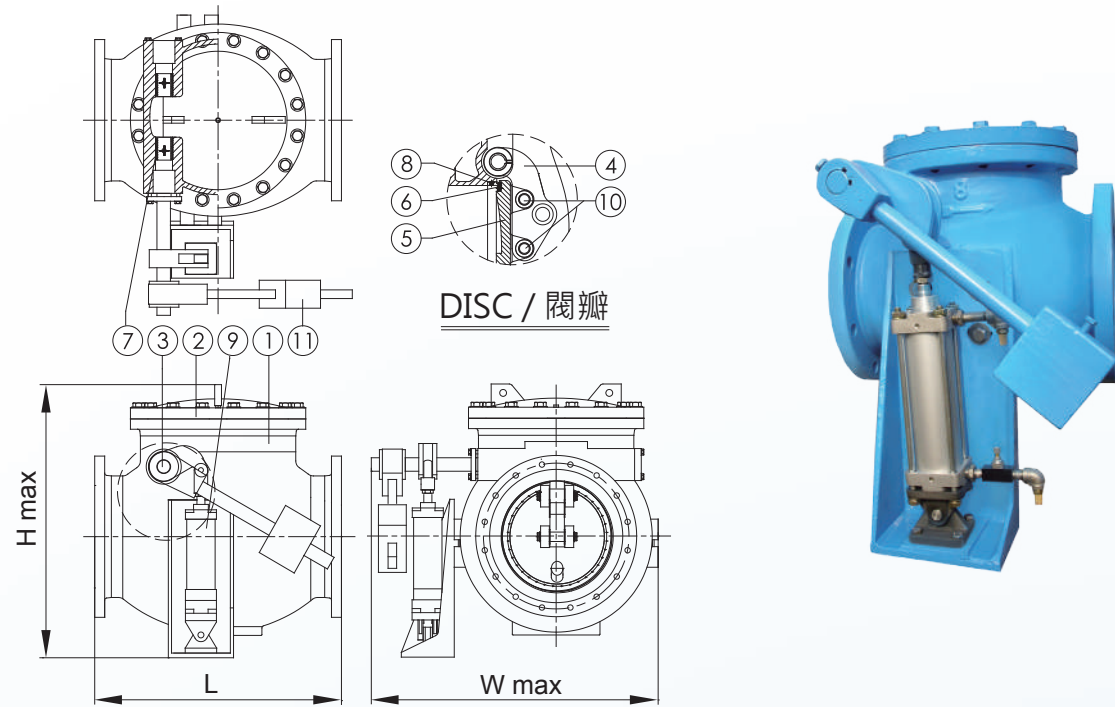

DIMENSION 尺寸表

unit : mm

DN DIM	75	100	125	150	200	250	300	350	400	450	500	600	750	900	1050
L	241	292	356	356	495	622	699	787	914	1016	1016	1219	1422	1600	1778
H max	585	585	600	600	725	740	860	945	1020	1145	1250	1350	1500	1760	2300
W max	400	450	510	510	650	760	850	1050	1200	1300	1330	1490	1630	2500	2800

PARTS & MATERIAL 零件材質表

NO.	PARTS 零件	MATERIAL 材質
1.	Body 閥體	DUCTILE CASTING IRON 球墨鑄鐵 / CASTING STEEL 鑄鋼
2.	Cover 閥蓋	DUCTILE CASTING IRON 球墨鑄鐵 / CASTING STEEL 鑄鋼
3.	Shaft 閥軸	STAINLESS STEEL 不銹鋼
4.	Arm 轉臂	STEEL 鋼製
5.	Disc 閥瓣	DUCTILE CASTING IRON 球墨鑄鐵 / CASTING STEEL 鑄鋼
6.	Disc Seat 座封	NBR / EPDM / VITON 合成橡膠
7.	Bearing 軸承	BRONZE 銅合金
8.	Body Seat 座圈	STAINLESS STEEL 不銹鋼
9.	Cylinder 緩衝缸	ALUMINIUM 鋁合金 / STAINLESS STEEL 不銹鋼/STEEL 鋼製
10.	Pin 固定銷	STAINLESS STEEL 不銹鋼
11.	Counter Weight 重錘	DUCTILE CASTING IRON 球墨鑄鐵

BUTTERFLY TYPE CHECK VALVES 蝶式逆止閥 $\Phi 100\sim\Phi 2000\text{mm}$ (4" ~ 80")

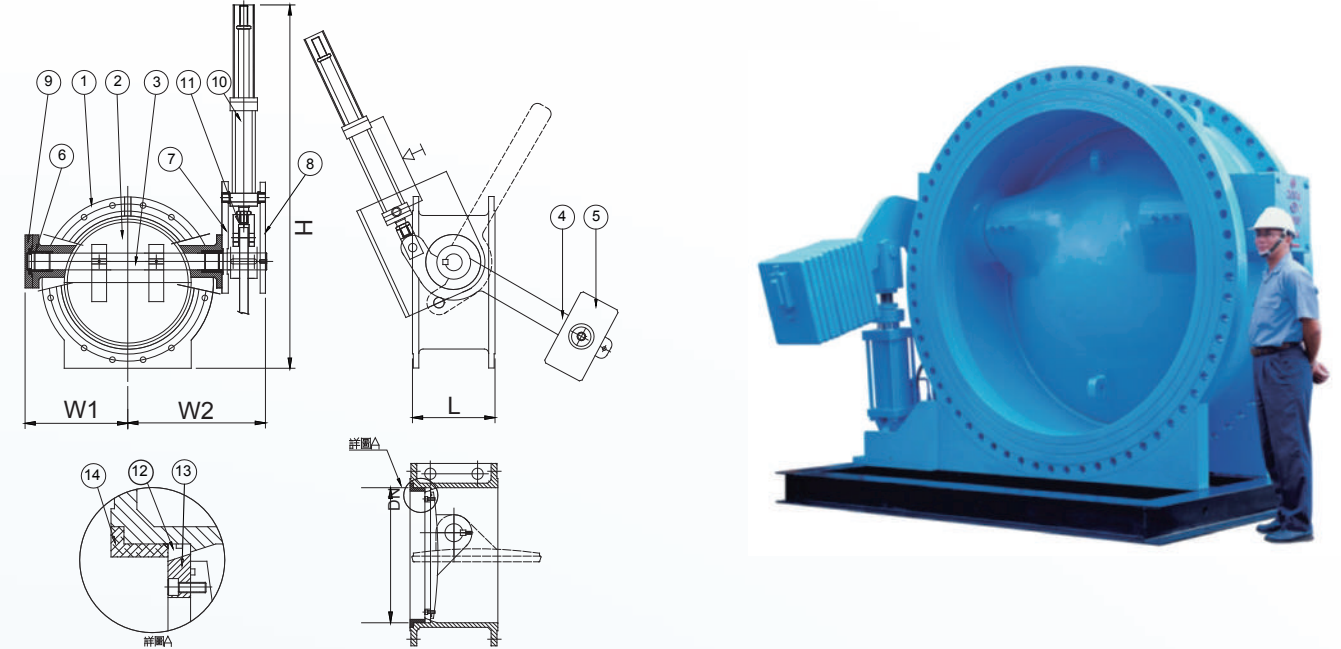

DIMENSION 尺寸表

unit : mm

DN DIM	100	200	250	300	350	400	450	500	600	700	800	900	1000	1200	1400	1600	1800	2000
L	190	230	250	270	290	310	330	350	390	430	470	510	550	630	710	790	870	950
H max	1200	1250	1300	1350	1450	1550	1650	1750	1850	2100	2350	2600	2850	3100	3400	3700	4000	4350
W1 max	200	250	300	350	400	450	500	550	600	650	700	750	800	900	1000	1100	1200	1400
W2 max	400	450	500	550	650	750	800	950	1000	1100	1200	1300	1450	1550	1650	1800	1950	2200

PARTS & MATERIAL 零件材質表

NO.	PARTS 零件	MATERIAL 材質
1.	Body 閥體	DUCTILE CASTING IRON 球墨鑄鐵 / CASTING STEEL 鑄鋼
2.	Disc 閥盤	DUCTILE CASTING IRON 球墨鑄鐵 / CASTING STEEL 鑄鋼
3.	Shaft 閥軸	STAINLESS STEEL 不銹鋼
4.	Arm 擺臂	STEEL 鋼製
5.	Counter Weight 重錘	DUCTILE CASTING IRON 球墨鑄鐵
6.	Bearing 軸襯	BRONZE 銅合金
7.	Frame 油壓鋼支架(一)	STEEL 鋼製
8.	Frame 油壓鋼支架(二)	STEEL 鋼製
9.	Cap 尾蓋	DUCTILE CASTING IRON 球墨鑄鐵 / CASTING STEEL 鑄鋼
10.	Cylinder 緩衝缸	STAINLESS STEEL 不銹鋼/STEEL 鋼製
11.	Connector 接頭	STEEL 鋼製
12.	Body Seat 座圈	STAINLESS STEEL 不銹鋼
13.	Disc Seat 閥座	BRONZE 銅合金
14.	Stop Ring 檔圈	DUCTILE CASTING IRON 球墨鑄鐵 / CASTING STEEL 鑄鋼 / STAINLESS STEEL 不銹鋼

SLANT TYPE CHECK VALVES WITH CUSHION CYLINDER
 斜盤式逆止閥附緩衝缸 $\Phi 150\sim\Phi 2000\text{mm}$ (6" ~ 80")

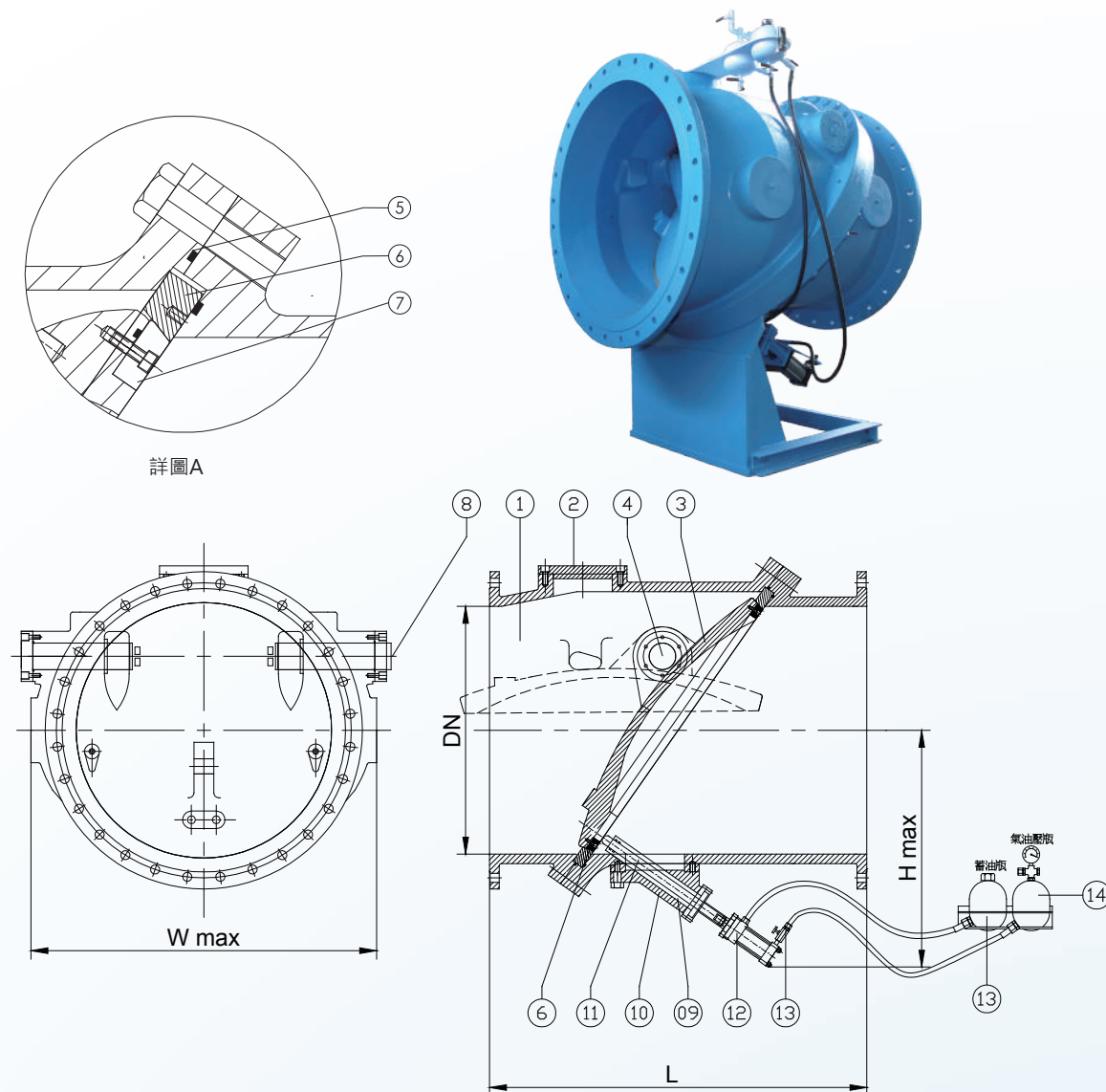

DIMENSION 尺寸表

unit : mm

DN DIM	150	200	250	300	350	400	450	500	600	700
L	380	495	620	610	760	760	840	815	995	1320
H max	400	450	500	550	600	650	700	750	800	900
W max	450	500	650	700	800	900	950	1100	1300	1500

DN DIM	800	900	1000	1100	1200	1350	1500	1650	1800	2000
L	1390	1510	1590	1590	1650	1980	2210	2500	2700	2900
H max	990	1050	1300	1300	1300	1600	1800	2000	2200	2400
W max	1700	1900	2000	2100	2300	2550	2700	2850	3000	3300

SLANT TYPE CHECK VALVES WITH EXTERNAL DRIVE
 斜盤式逆止閥附外部控制裝置 $\Phi 150\sim\Phi 1000\text{mm}$ (6" ~ 40")

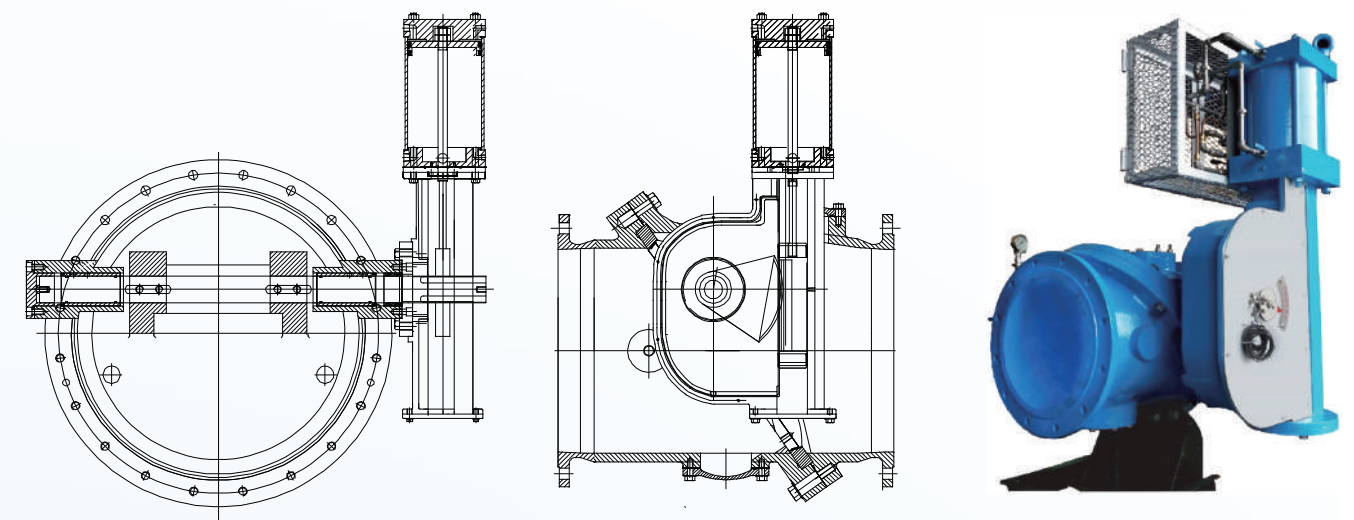

PARTS & MATERIAL 零件材質表

NO.	PARTS 零件	MATERIAL 材質
1.	Body 閥體	DUCTILE CASTING IRON 球墨鑄鐵 / CASTING STEEL 鑄鋼
2.	Cover 閥蓋	DUCTILE CASTING IRON 球墨鑄鐵 / CASTING STEEL 鑄鋼
3.	Disc 閥瓣	DUCTILE CASTING IRON 球墨鑄鐵 / CASTING STEEL 鑄鋼
4.	Shaft 閥軸	STAINLESS STEEL 不銹鋼
5.	Seal 水封	NBR / EPDM 合成橡膠
6.	Body Seat 閥體座圈	BRONZE 銅合金
7.	Disc Seat 閥座	STAINLESS STEEL 不銹鋼
8.	Position Indicator 開度指示器	DUCTILE CASTING IRON 球墨鑄鐵 / STAINLESS STEEL 不銹鋼
9.	Rod Bushing 緩衝桿套	BRONZE 銅合金
10.	Cushion Base 緩衝基座	DUCTILE CASTING IRON 球墨鑄鐵
11.	Cushion Rod 緩衝桿	STAINLESS STEEL 不銹鋼
12.	Cylinder 緩衝缸	STAINLESS STEEL 不銹鋼/STEEL 鋼製
13.	Flow Control Valve 流量控制閥	STAINLESS STEEL 不銹鋼/STEEL 鋼製
14.	Hydro-Pneumatic Tank 氣油壓瓶	STEEL 鋼製
15.	Oil Reservoir 蓄油瓶	STEEL 鋼製

RUBBER FLAPPER SWING CHECK VALVES 橡膠閥瓣逆止閥 $\Phi 50\sim\Phi 1200$ mm (2" - 48")

General type 一般型

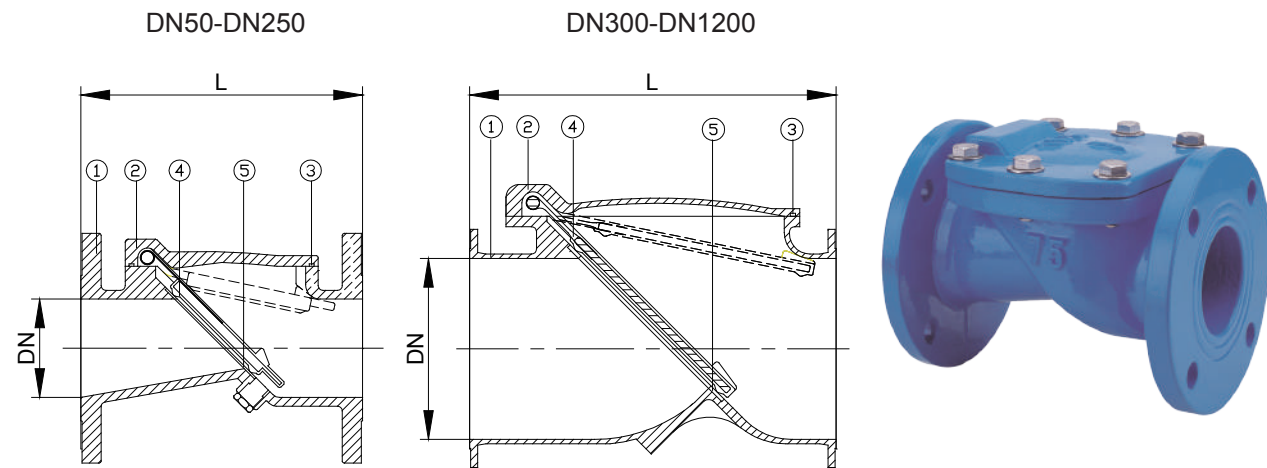

DIMENSION 尺寸表

unit : mm

DN DIM	50	75	100	150	200	250	300	350	400	450	500	600	700	800	900	1000	1100	1200
L	203	241	292	356	495	622	698	787	914	1016	1016	1219	1448	1524	1750	1960	2160	2350

Pushing Stick type 推桿型

For reverse cleansing 應用於反沖洗系統

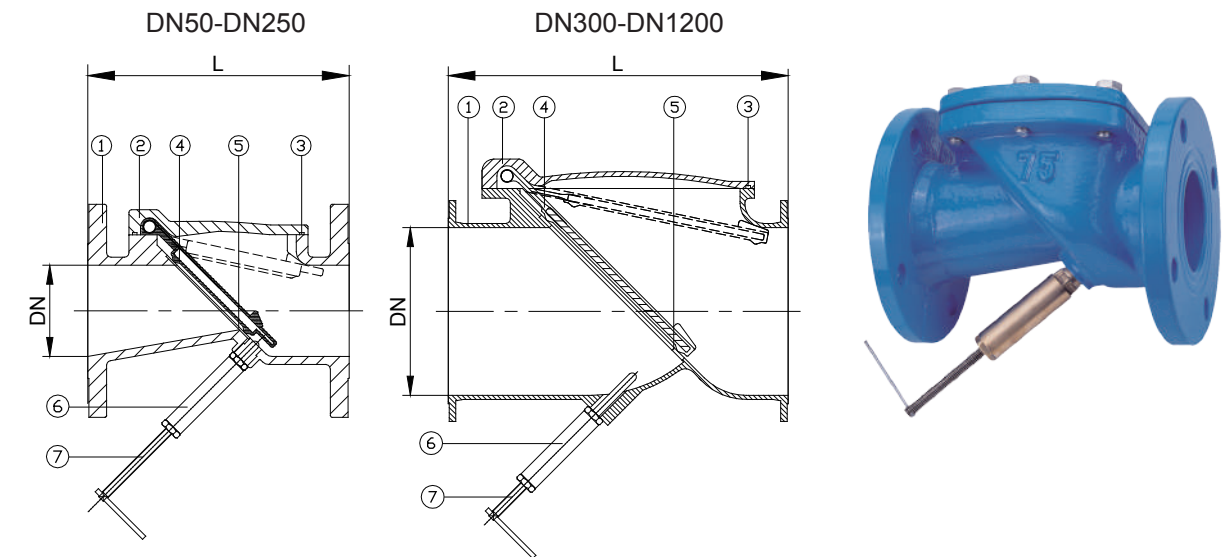

DIMENSION 尺寸表

unit : mm

DN DIM	50	75	100	150	200	250	300	350	400	450	500	600	700	800	900	1000	1100	1200
L	203	241	292	356	495	622	698	787	914	1016	1016	1219	1448	1524	1750	1960	2160	2350

PARTS & MATERIAL 零件材質表

NO.	PARTS 零件	MATERIAL 材質
1.	Body 閥體	DUCTILE CASTING IRON 球墨鑄鐵 / CASTING STAINLESS STEEL 鑄不銹鋼
2.	Cover 閥蓋	DUCTILE CASTING IRON 球墨鑄鐵 / CASTING STAINLESS STEEL 鑄不銹鋼
3.	Seal 水封	NBR / EPDM 合成橡膠
4.	Plate & Rod 平板及桿	DUCTILE CASTING IRON 球墨鑄鐵 / STEEL 鋼製 / STAINLESS STEEL 不銹鋼
	Flapper 閥瓣包膠	NBR / EPDM / VITON (NYLON FIBER REINFORCED) 合成橡膠(強化尼龍纖維補強)
5.	Seat 閥座	STAINLESS STEEL 不銹鋼

PARTS & MATERIAL 零件材質表

NO.	PARTS 零件	MATERIAL 材質
1.	Body 閥體	DUCTILE CASTING IRON 球墨鑄鐵 / CASTING STAINLESS STEEL 鑄不銹鋼
2.	Cover 閥蓋	DUCTILE CASTING IRON 球墨鑄鐵 / CASTING STAINLESS STEEL 鑄不銹鋼
3.	Seal 水封	NBR / EPDM 合成橡膠
4.	Plate & Rod 平板及桿	DUCTILE CAST IRON 球墨鑄鐵 / STEEL 鋼製 / STAINLESS STEEL 不銹鋼
	Flapper 閥瓣包膠	NBR / EPDM / VITON (NYLON FIBER REINFORCED) 合成橡膠(強化尼龍纖維補強)
5.	Seat 閥座	STAINLESS STEEL 不銹鋼
6.	Slide Guide 套筒	STEEL 鋼製 / STAINLESS STEEL 不銹鋼
7.	Pushing Stick 推桿	STAINLESS STEEL 不銹鋼

RUBBER FLAPPER SWING CHECK VALVES WITH CUSHION CYLINDER
橡膠閘瓣逆止閘附緩衝缸 Φ100~ Φ1200mm (2" ~ 48")
 (通用於泵浦前端)

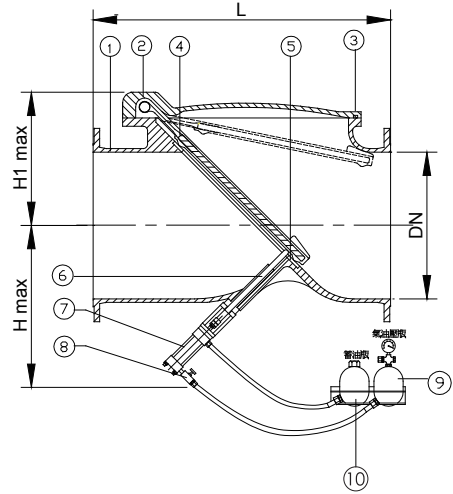

DIMENSION 尺寸表

unit : mm

DN DIM	100	150	200	250	300	350	400	450	500	600	700	800	900	1000	1100	1200
L	292	356	495	622	698	787	914	1016	1016	1219	1448	1524	1750	1960	2160	2350
H max	260	270	280	300	600	660	690	770	810	900	1040	1130	1260	1300	1350	1400
H1 max	190	210	235	250	330	380	400	530	530	690	690	820	930	1100	1150	1200

PARTS & MATERIAL 零件材質表

NO.	PARTS 零件	MATERIAL 材質
1.	Body 閘體	DUCTILE CASTING IRON 球墨鑄鐵 / CASTING STAINLESS STEEL 鑄不銹鋼
2.	Cover 閘蓋	DUCTILE CASTING IRON 球墨鑄鐵 / CASTING STAINLESS STEEL 鑄不銹鋼
3.	Seal 水封	NBR / EPDM 合成橡膠
4.	Plate & Rod 平板及桿	DUCTILE CASTING IRON 球墨鑄鐵 / STEEL 鋼製 / STAINLESS STEEL 不銹鋼
	Flapper 閘瓣包膠	NBR / EPDM / VITON (NYLON FIBER REINFORCED) 合成橡膠(強化尼龍纖維補強)
5.	Seat 閘座	STAINLESS STEEL 不銹鋼
6.	Cushion Rod 推桿	STAINLESS STEEL 不銹鋼
7.	Cylinder 緩衝缸	STEEL 鋼製 / STAINLESS STEEL 不銹鋼
8.	Flow Control Valve 流量控制閘	STEEL 鋼製 / STAINLESS STEEL 不銹鋼
9.	Hydro-Pneumatic Tank 氣油壓瓶	STEEL 鋼製
10.	Oil Reservoir 蓄油瓶	STEEL 鋼製

SINGLE PLATE CHECK VALVES-FLANGE TYPE 單辦法蘭型逆止閘
Φ100~Φ600mm (4" ~ 24")

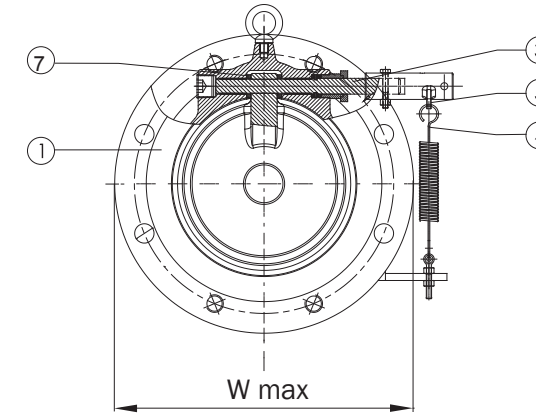
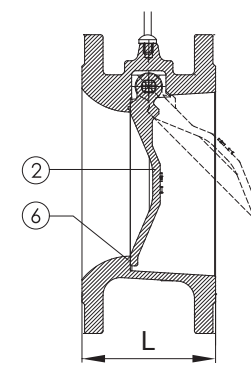

DIMENSION 尺寸表

unit : mm

DN DIM	100	125	150	200	250	300	350	400	450	500	600
L	127	140	140	152	165	178	190	216	222	229	267
W max	260	275	310	365	430	485	550	600	670	725	860

PARTS & MATERIAL 零件材質表

NO.	PARTS 零件	MATERIAL 材質
1.	Body 閘體	DUCTILE CASTING IRON 球墨鑄鐵 / CASTING STAINLESS STEEL 鑄不銹鋼
2.	Plate 閘瓣	STAINLESS STEEL 不銹鋼
3.	Shaft 閘軸	STAINLESS STEEL 不銹鋼
4.	Spring 彈簧	STAINLESS STEEL 不銹鋼 / STEEL 鋼製
5.	Spring Adaptor 彈簧連接座	STEEL 鋼製
6.	Seat 座封	NBR / EPDM / VITON 合成橡膠
7.	Bearing 軸承	BRONZE 銅合金 / TEFLON 鐵氟龍

SINGLE PLATE CHECK VALVE-LONG TYPE 單瓣厚型逆止閥 $\Phi 50\text{-}\Phi 350\text{mm}$ (2" ~ 14")

SINGLE PLATE CHECK VALVE-SHORT TYPE 單瓣薄型逆止閥 $\Phi 25\text{-}\Phi 600\text{mm}$ (2" ~ 24")

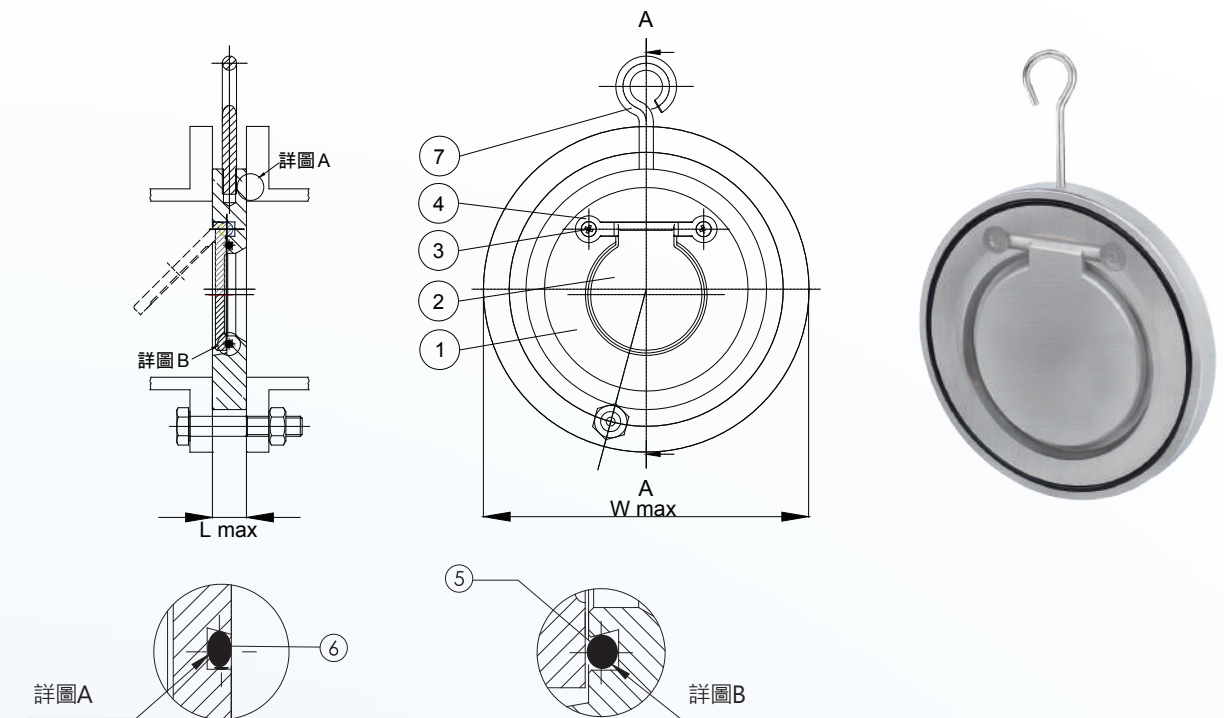
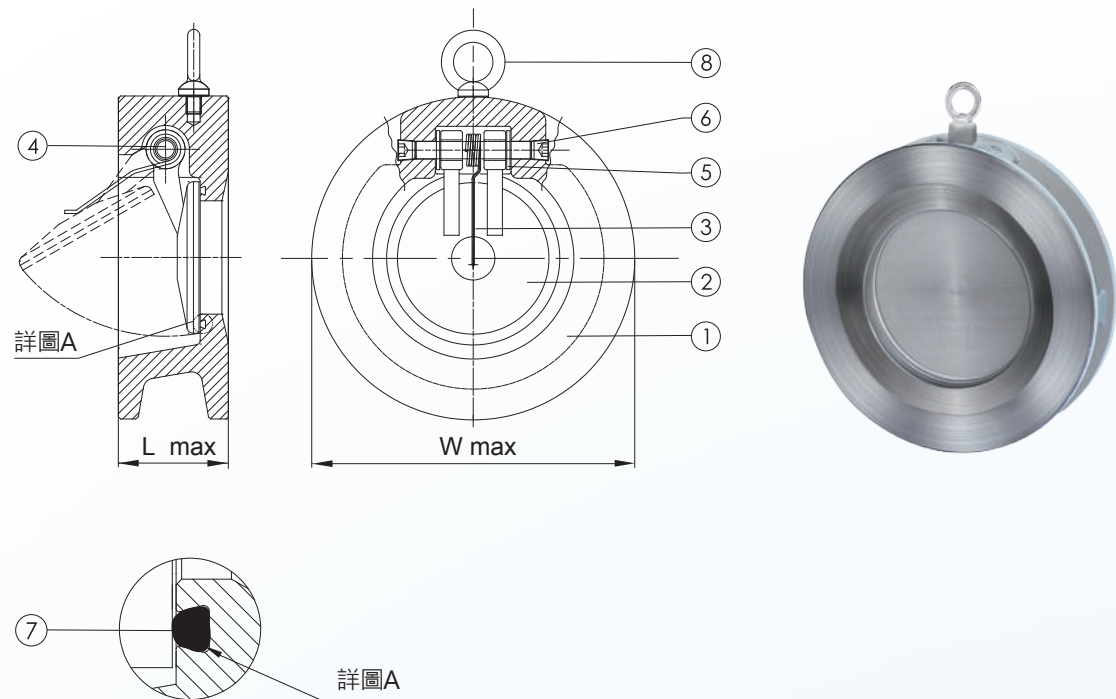

DIMENSION 尺寸表

unit : mm

DN DIM	50	65	80	100	125	150	200	250	300	350
W max	130	145	170	200	230	270	330	380	440	505
L max	45	50	52	60	65	70	75	80	90	108

DIMENSION 尺寸表

unit : mm

DN DIM	25	40	50	65	80	100	125	150	200	250	300	350	400	450	500	600
W max	90	110	130	145	170	200	235	270	330	400	440	510	560	620	710	800
L max	35	35	35	35	35	35	35	40	50	60	70	70	70	95	100	110

PARTS & MATERIAL 零件材質表

NO.	PARTS 零件	MATERIAL 材質
1.	Body 閥體	DUCTILE CASTING IRON 球墨鑄鐵 / CASTING STEEL 鑄鋼 CASTING STAINLESS STEEL 鑄不銹鋼
2.	Plate 閥瓣	STAINLESS STEEL 不銹鋼
3.	Spring 彈簧	STAINLESS STEEL 不銹鋼 / ALLOY STEEL 合金鋼
4.	Hinge Pin 閥桿	STAINLESS STEEL 不銹鋼
5.	Body Bearing 閥體軸承	STAINLESS STEEL 不銹鋼 / TEFLON 鐵弗龍
6.	Retainer 固定器	STEEL 鋼製 / STAINLESS STEEL 不銹鋼
7.	Seat 座封	NBR / EPDM / VITON 合成橡膠 / STAINLESS STEEL 不銹鋼
8.	Eye Bolt 吊耳	STEEL 鋼製

PARTS & MATERIAL 零件材質表

NO.	PARTS 零件	MATERIAL 材質
1.	Body 閥體	CARBON STEEL 碳鋼 / STAINLESS STEEL 不銹鋼
2.	Plate 閥瓣	STAINLESS STEEL 不銹鋼
3.	Retainer 固定器	STAINLESS STEEL 不銹鋼
4.	Bushing 軸襯	STAINLESS STEEL 不銹鋼
5.	Seat 座封	STAINLESS STEEL 不銹鋼 / NBR / EPDM / VITON 合成橡膠 TEFLON 鐵弗龍
6.	O Ring 套環接頭	ALLOY STEEL 合金鋼
7.	Eye Bolt 吊耳	STAINLESS STEEL 不銹鋼

DUAL PLATE CHECK VALVE WITH RUBBER SEAT 雙瓣彈簧式逆止閥 Φ50~Φ900mm (2" ~ 36")

FOR API STANDARD

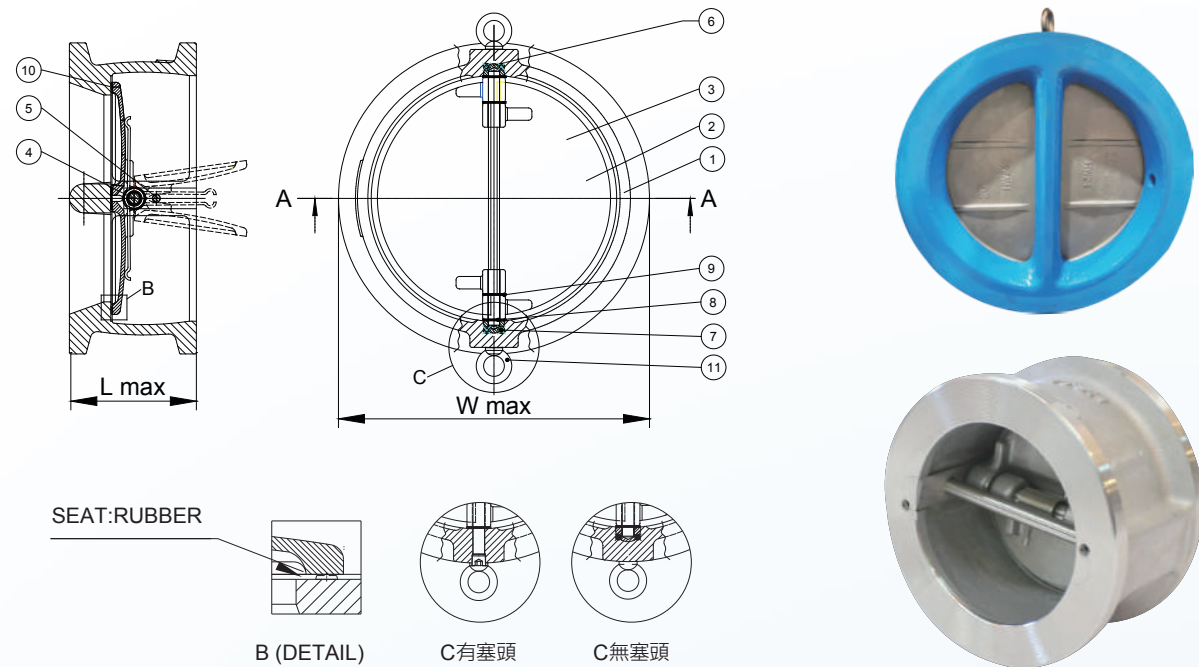

DIMENSION 尺寸表

unit : mm

DN DIM	50	75	100	150	200	250	300	350	400	450	500	600	700	800	900	1000
L (7.5K、16K)	54	57	64	76	95	108	143	184	191	203	213	222	321	356	368	405
W max (7.5K)	101	149	176	228	280	337	391	447	499	558	612	716	821	927	1040	1146
W max (10K)	101	131	156	217	267	330	375	420	483	538	592	695	807	917	1017	1121

PARTS & MATERIAL 零件材質表

NO.	PARTS 零件	MATERIAL 材質
1.	Body 閥體	CASTING IRON 鑄鐵 / DUCTILE CASTING IRON 球墨鑄鐵 CARBON STEEL 碳鋼 / CASTING STAINLESS STEEL 鑄不銹鋼
2.	Plate 閥瓣	CASTING STAINLESS STEEL 鑄不銹鋼 / CASTING STEEL 鑄鋼
3.	Spring 彈簧	STAINLESS STEEL 不銹鋼 / ALLOY STEEL 合金鋼
4.	Hinge Pin 閥桿	STAINLESS STEEL 不銹鋼
5.	Stop Pin 阻桿	STAINLESS STEEL 不銹鋼
6.	Carrier 傳動軸	CAST STEEL 鑄鋼 / STAINLESS STEEL 不銹鋼
7.	Retainer Screw 固定器螺絲	STAINLESS STEEL 不銹鋼
8.	Body Washer 閥體墊圈	TEFLON 鐵弗龍 / STAINLESS STEEL 不銹鋼
9.	Plate Washer 閥瓣墊圈	TEFLON 鐵弗龍 / STAINLESS STEEL 不銹鋼
10.	Seat 座封	NBR / EPDM / VITON 合成橡膠 / STAINLESS STEEL 不銹鋼
11.	Eye Bolt 吊耳	ALLOY STEEL 合金鋼 / STAINLESS STEEL 不銹鋼

DUAL PLATE CHECK VALVE WITH FULL RUBBER 全包雙瓣彈簧式逆止閥 Φ50~Φ600mm (2" ~ 24")

FOR SEA WATER AND CHEMICAL FLUID 應用於海水及化學液體

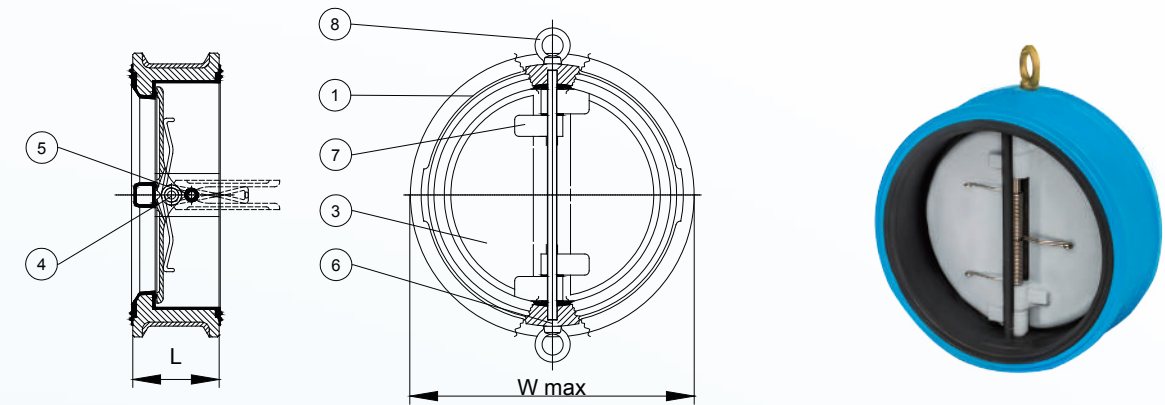

DIMENSION 尺寸表

unit : mm

DN DIM	50	75	100	150	200	250	300	350	400	450	500	600	700	800	900	1000
L (7.5K、16K)	54	57	64	76	95	108	143	184	191	203	213	222	321	356	368	405
W max (7.5K)	101	149	176	228	280	337	391	447	499	558	612	716	821	927	1040	1146
W max (10K)	101	131	156	217	267	330	375	420	483	538	592	695	807	917	1017	1121

PARTS & MATERIAL 零件材質表

NO.	PARTS 零件	MATERIAL 材質
1.	Body 閥體	CASTING IRON 鑄鐵 / DUCTILE CASTING IRON 球墨鑄鐵 CARBON STEEL 碳鋼
2.	Plate 閥瓣	CARBON STEEL 碳鋼 / STAINLESS STEEL 不銹鋼 / ALBC 鋁青銅
3.	Spring 彈簧	INCONEL ALLOY 鉻鎳鐵合金 / STAINLESS STEEL 不銹鋼
4.	Hinge Pin 閥桿	STAINLESS STEEL 不銹鋼
5.	Stop Pin 阻桿	STAINLESS STEEL 不銹鋼
6.	Retainer 固定器	ALLOY STEEL 合金鋼
7.	Seat 座封	NBR / EPDM / VITON 合成橡膠
8.	Eye Bolt 吊耳	ALLOY STEEL 合金鋼

DUAL PLATE TYPE CHECK VALVES WITH BY PASS 雙瓣彈簧式逆止閥附旁通閥
Φ50~Φ1000mm (2" ~ 40")

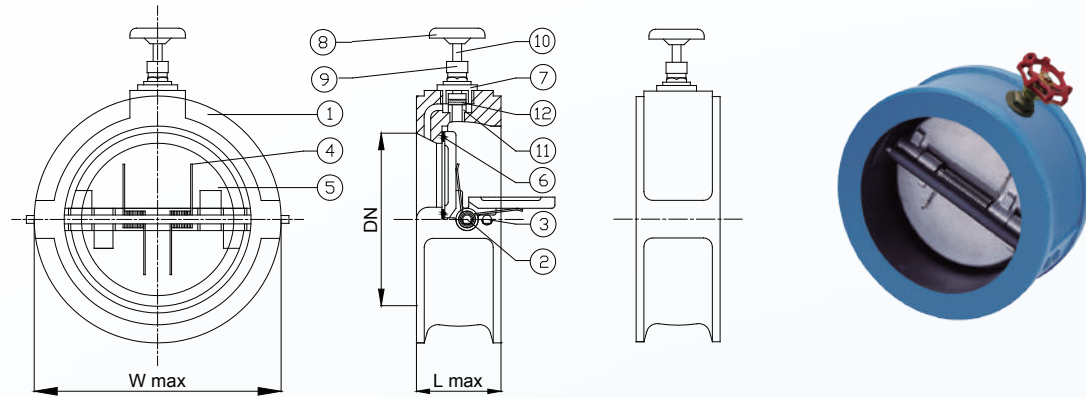

DIMENSION 尺寸表

unit : mm

DN DIM	50	75	100	150	200	250	300	350	400	450	500	600	700	800	900	1000
L (7.5K - 16K)	54	57	64	76	95	108	143	184	191	203	213	222	321	356	368	405
W max (7.5K)	101	149	176	228	280	337	391	447	499	558	612	716	821	927	1040	1146
W max (10K)	101	131	156	217	267	330	375	420	483	538	592	695	807	917	1017	1121

PARTS & MATERIAL 零件材質表

NO.	PARTS 零件	MATERIAL 材質
1.	Body 閥體	DUCTILE CAST IRON 球墨鑄鐵 / CASTING STAINLESS STEEL 鑄不銹鋼
2.	Hinge Pin 閥桿	STAINLESS STEEL 不銹鋼
3.	Stop Pin 阻桿	STAINLESS STEEL 不銹鋼
4.	Spring 彈簧	STAINLESS STEEL 不銹鋼
5.	Plate 閥瓣	CASTING STAINLESS STEEL 不銹鋼 / BRONZE 銅合金
6.	Seat 座封	NBR / EPDM / VITON 合成橡膠
7.	O Ring 套環接頭	NBR / EPDM / VITON 合成橡膠
8.	Handwheel 手輪	DUCTILE CASTING IRON 球墨鑄鐵
9.	By Pass 旁通閥	STAINLESS STEEL 不銹鋼 / BRONZE 銅合金
10.	Stem 桿	STAINLESS STEEL 不銹鋼 / BRONZE 銅合金
11.	Seal 水封	NBR / EPDM / VITON 合成橡膠

BALL TYPE CHECK VALVE 球式逆止閥 Φ50~Φ500mm (2" ~ 20")

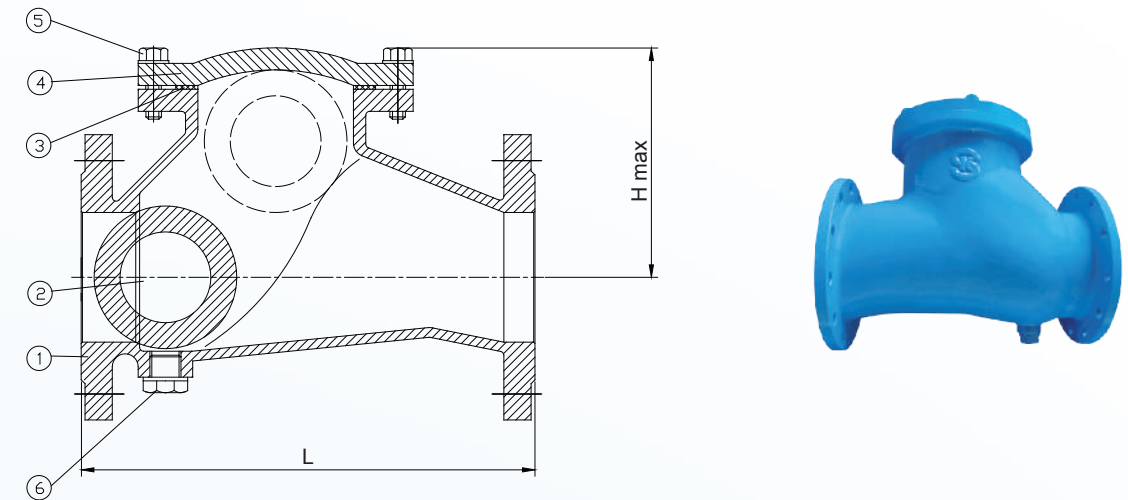

DIMENSION 尺寸表

unit : mm

DN DIM	40	50	65	80	100	125	150	200	250	300	400	500
L	180	200	240	260	300	350	400	500	600	700	900	1100
H max	120	135	145	150	180	230	245	310	390	460	610	770

PARTS & MATERIAL 零件材質表

NO.	PARTS 零件	MATERIAL 材質
1.	Body 閥體	DUCTILE CASTING IRON 球墨鑄鐵
2.	Float Ball 浮球	STEEL COVERD WITH EPDM 鋼材被覆橡膠
3.	Gasket 墊片	NBR / EPDM / VITON 合成橡膠
4.	Cover 閥蓋	DUCTILE CASTING IRON 球墨鑄鐵
5.	Bolts 螺栓	STEEL 鋼製 / STAINLESS STEEL 不銹鋼
6.	Plug 塞頭	STEEL 鋼製 / STAINLESS STEEL 不銹鋼

NOZZLE TYPE CHECK VALVES 環狀噴流式逆止閥 $\Phi 75\sim\Phi 300\text{mm}$ (3" ~ 12")

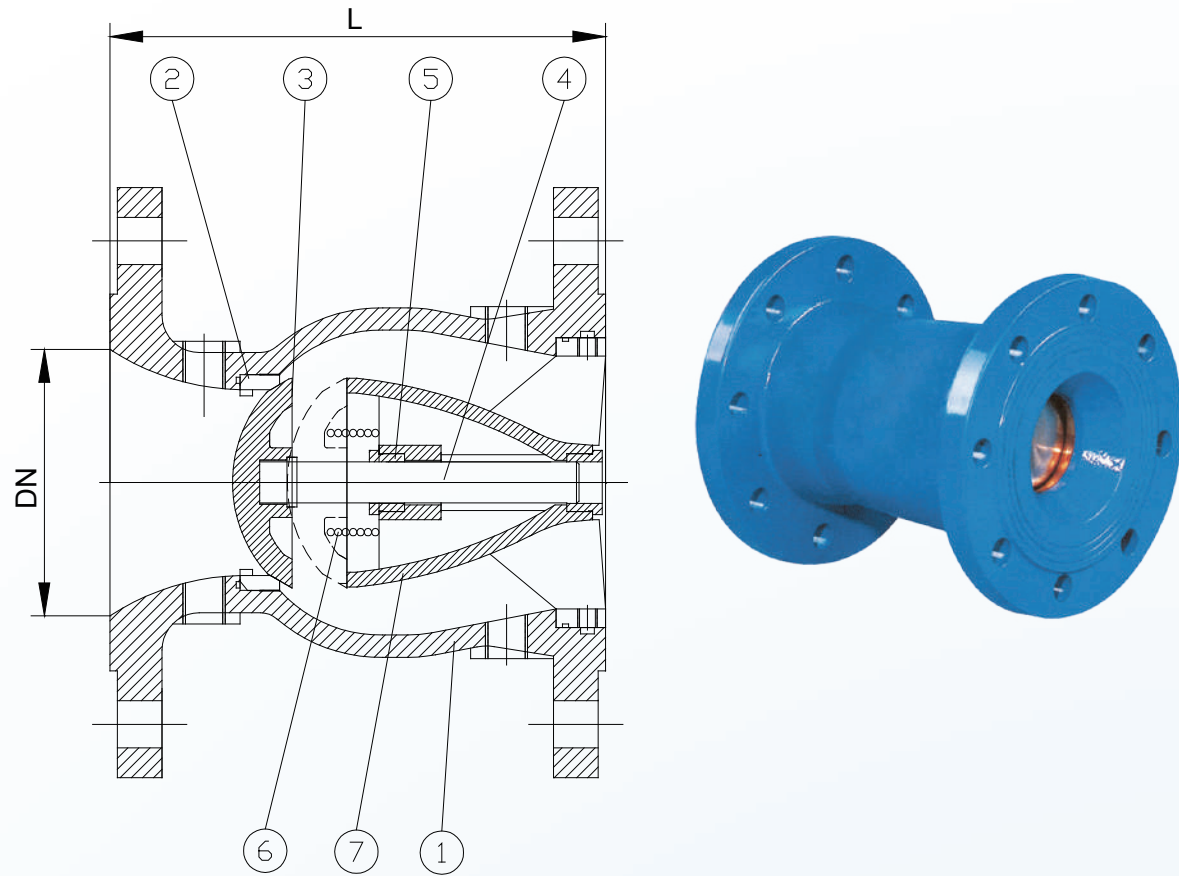

DIMENSION 尺寸表 unit : mm

DN DIM	75	100	150	200	250	300
L	150	200	300	400	500	550

PARTS & MATERIAL 零件材質表

NO.	PARTS 零件	MATERIAL 材質
1.	Body 閥體	DUCTILE CASTING IRON 球墨鑄鐵
2.	Seat 座封	ALBC 鋁青銅
3.	Disc 閥瓣	ALBC 鋁青銅
4.	Axis 閥軸	STAINLESS STEEL 不銹鋼
5.	Slide Guide 滑套	PHOSPHOR BRONZE 磷青銅
6.	Spring 彈簧	STAINLESS STEEL 不銹鋼
7.	Flow Guide 導流體	DUCTILE CASTING IRON 球墨鑄鐵

NOZZLE TYPE CHECK VALVES 環狀噴流式逆止閥 $\Phi 400\sim\Phi 1000\text{mm}$ (16" ~ 40")

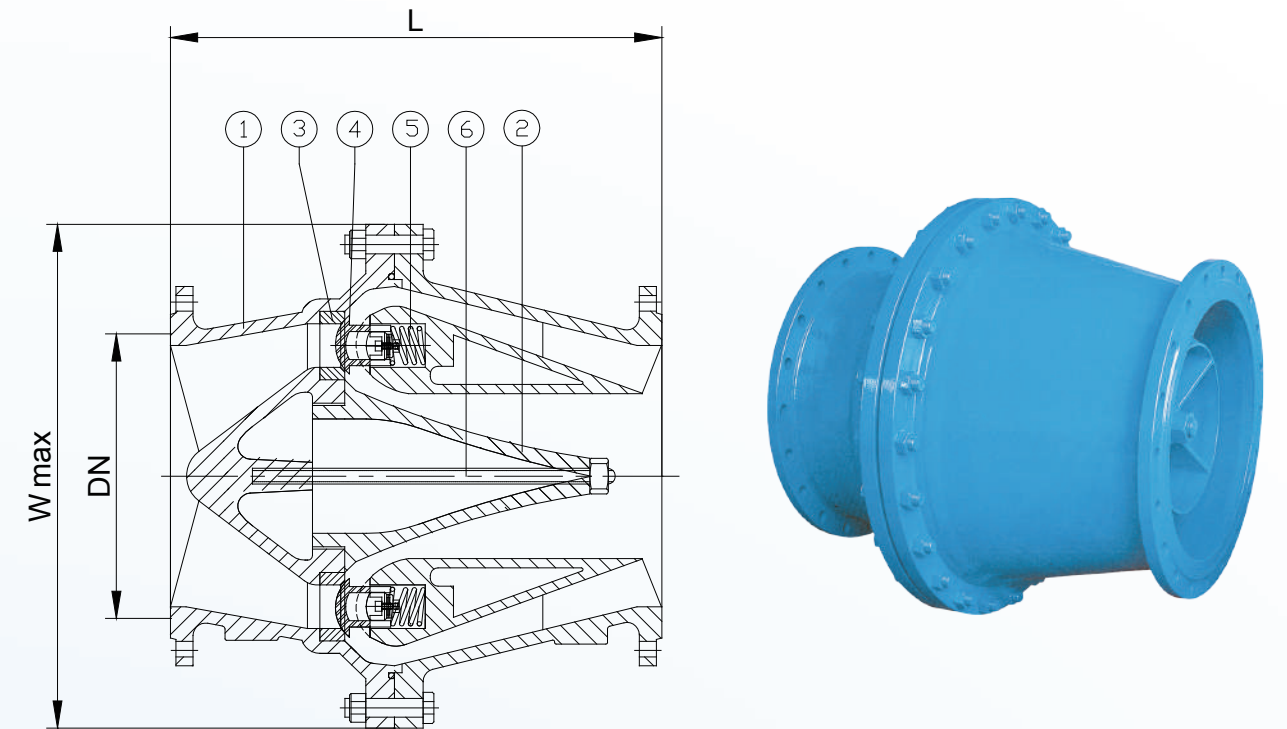

DIMENSION 尺寸表 unit : mm

DN DIM	400	500	600	700	800	900	1000
L	680	850	1020	1190	1360	1530	1700
W max	800	950	1100	1250	1400	1600	1750

PARTS & MATERIAL 零件材質表

NO.	PARTS 零件	MATERIAL 材質
1.	Body 閥體	DUCTILE CASTING IRON 球墨鑄鐵
2.	Flow Guide 導流體	DUCTILE CASTING IRON 球墨鑄鐵
3.	Seat 座封	ALBC 鋁青銅
4.	Disc 閥瓣	ALBC 鋁青銅
5.	Spring 彈簧	STAINLESS STEEL 不銹鋼
6.	Axis 閥軸	STAINLESS STEEL 不銹鋼