

INSTALLATION INSTRUCTIONS 安裝方式

Horizontal installation 水平安裝

Clean water installation recommendations 清水安裝建議

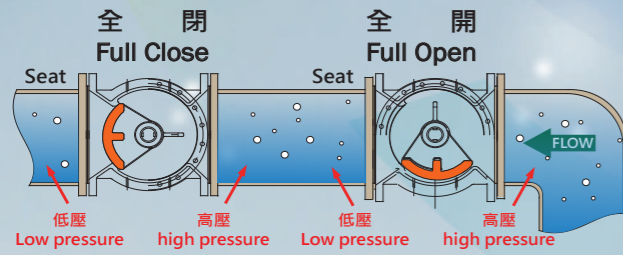

Sewage installation recommendations 污水安裝建議
Contains suspended debris or sediment (含懸浮雜物或泥沙)

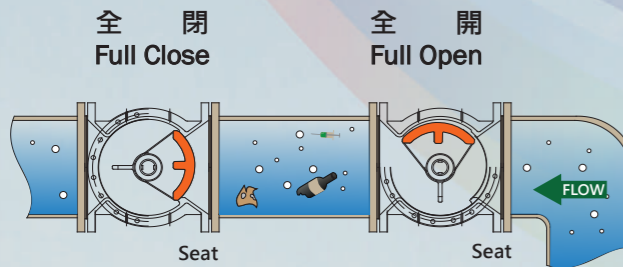

Vertical installation 垂直安裝

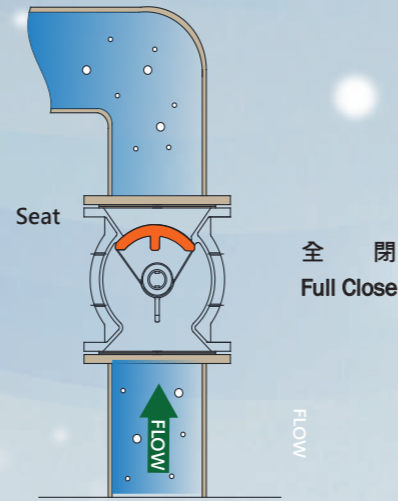

Since 1966



SK VALVES

ECCENTRIC PLUG VALVES 偏心柱塞閥



Lever Type ■
把手型柱塞閥 $\Phi 50 \sim \Phi 200\text{mm}$
(2" ~ 8")

Worm Gear Type ■
減速機型柱塞閥 $\Phi 80 \sim \Phi 1200\text{mm}$
(3" ~ 48")



SPECIFICATIONS 規格說明

CLASS & FLANGE STANDARD 壓力等級 & 法蘭規格			Fluid 適用流體	
Standard 規格	Class 等級	Pressure 工作壓力	Raw Water / Sewage 原水、污水	
ANSI	125LB	0 - 125 psi	Temperature Range 流體溫度 0 - 80 °C / 32 - 176 °F	
	150LB	0 - 150 psi		
	250LB	0 - 250 psi		
	300LB	0 - 300 psi		
ISO DIN BS	PN10	0 - 10 kgf/cm ²	Testing Pressure 測試壓力 ACCORDING TO ISO 5208 (RATE 3) SEAT 閥座 : 1.1 × MAX.OPERATING PRESSURE BODY 閥體 : 1.5 × MAX.OPERATING PRESSURE	
	PN16	0 - 16 kgf/cm ²		
	PN25	0 - 25 kgf/cm ²		
JIS CNS	7.5K	0 - 7.5 kgf/cm ²		
	10K	0 - 10 kgf/cm ²		
	16K	0 - 16 kgf/cm ²		

叶光閥業股份有限公司 SHYE KUANG VALVES MFG CO.,LTD.
恩盈企業股份有限公司 EN IN ENTERPRISE CO.,LTD.

■ 總公司 Headquarter
923屏東縣萬巒鄉佳興路83號 No. 83, Chia-Hsing Rd., Wan-Luan, Pingtung 923, Taiwan R.O.C.
TEL : +886-8-783-3834 FAX : +886-8-783-3734 Skype: skvalve.andrew
E-mail: international@skvalves.com.tw

■ 北區辦公室 North Taiwan Office
241新北市三重區環河北路三段270號1樓
No. 270, Sec. 3, Huanhe N. Rd., Sanchong Dist., New Taipei City 241076, Taiwan R.O.C.
TEL : +886-2-2988-4657 FAX : +886-2-2988-4657



www.skvalves.com.tw

■ 本公司對型錄所列之材質與尺寸保留認為必要時作修改之權利，或依客戶需求設計，實際尺寸及材質仍以客戶訂購時所提供之圖說為準。

SK Valves reserves the right to modify the materials or/and dimensions of the products as provided hereunder from time to time if necessary, or in accordance with the request of clients. The actual dimensions or/and material used are subject to the customer's request after placing the order.

PRODUCT DESCRIPTION 產品概說

- Plug valves are covered with EPDM, which enhance the sealing ability and prevent leakage when the valve is closed.
閥栓採用高級橡膠包覆，在閥栓關閉時，能有效關斷，避免滲漏。
- When the plug valve opens, the plug immediately shifts away from the valve seat. Once the plug's edge is aligned with the upper edge body, it is considered the open position of the valve.
當栓塞開啓時，栓塞與閥座立即偏移，待栓塞至貼近管線上緣時，即為閥開啓位置。
- When used in elevated drainage systems, plug valves primarily serve as the shut-off valve and do not have flow control capabilities; therefore, they should be installed at the pipeline outlet to ensure the valve can function adequately.
用於高架排水系統時，因其栓塞閥主要功能在於全關 / 全開等狀態，並無調流功能，所以裝設栓塞閥應將栓塞面對出水口的位置安裝，確保閥能發揮正常開 / 關等功能。
- Applicable for sewage plant's pipeline and relative facility.
應將栓塞面對出水口的位置安裝，確保閥能發揮正常開 / 關等功能。

FEATURES 設計特點

- The internal design of the valve body creates turbulence to prevent sedimentation of silt and sand inside the valve. The flow area can reach more than 80%, reducing the accumulation of impurities buildup over time.
閥體內部特殊設計，使閥體內部產生擾流，避免泥沙沉積，其水流面積可達80%以上，減少雜質淤積於閥體內。
- The eccentric design is deployed to the shaft and the seat to make the operation more efficient and reduce wear between parts.
閥座與閥軸採偏心式設計，使操作更為省力，並有效降低閥座磨損。
- Adjustable valve stem packing design allows users to adjust on-site without disassembling the attached driving module.
可調整式閥軸填料設計，可在現場隨時調整，不必拆卸操作機。
- Handle type, worm gear type, or motorized are available upon customer request.
可依實際需要選擇把手式、渦齒式、或電動機操作方式。

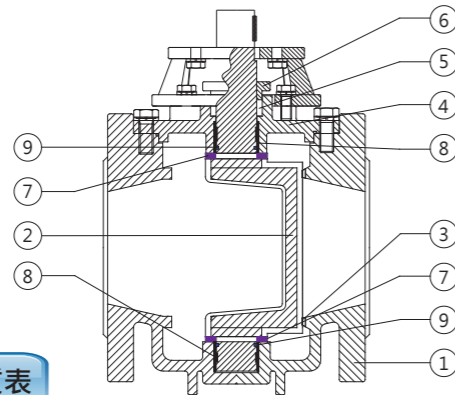

PARTS & MATERIAL 零件材質表

NO.	PARTS 零件	MATERIAL 材質
1.	Body 閥體	DUCTILE CAST IRON 球墨鑄鐵 / SCS 鑄不銹鋼
2.	Plug 栓塞	DUCTILE CAST IRON 球墨鑄鐵 / SCS 鑄不銹鋼 / COVERED WITH EPDM 被覆合成橡膠
3.	Seat 閥座	STAINLESS STEEL 不銹鋼
4.	Cover 閥蓋	DUCTILE CAST IRON 球墨鑄鐵 / SCS 鑄不銹鋼
5.	Packing 纖維填料	VIRGIN PTFE 鐵弗龍纖維
6.	Gland 填料壓蓋	DUCTILE CAST IRON 球墨鑄鐵 / SCS 鑄不銹鋼
7.	Washer 墊片	STAINLESS STEEL 不銹鋼
8.	Bushing 軸襯	STAINLESS STEEL 不銹鋼
9.	O-ring 軸封	NBR / EPDM / VITON 合成橡膠

LEVER TYPE PLUG VALVE 把手型栓塞閥 Φ50~Φ200mm

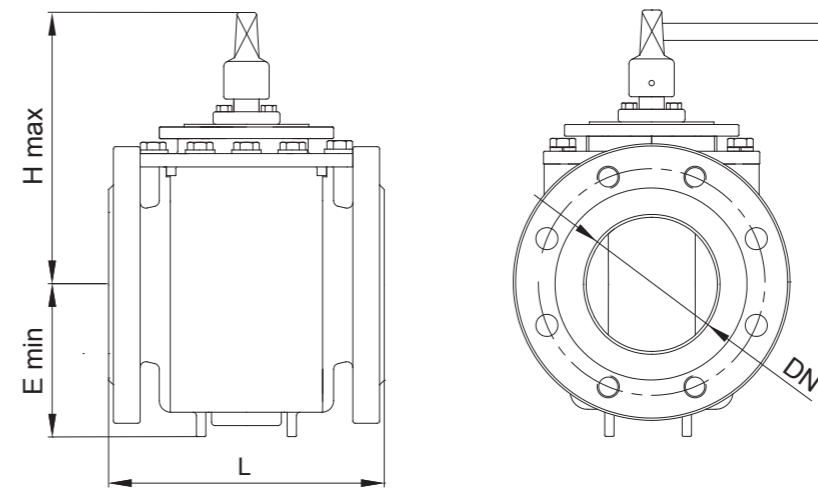

DIMENSION 尺寸表 unit : mm

DIM SIZE	L	E (min)	H (max)
50	178	50	150
80	203	100	200
100	229	120	300
125	229	120	350
150	267	150	400
200	292	150	450

WORM GEAR TYPE PLUG VALVE 減速機型栓塞閥 Φ80~Φ1200mm

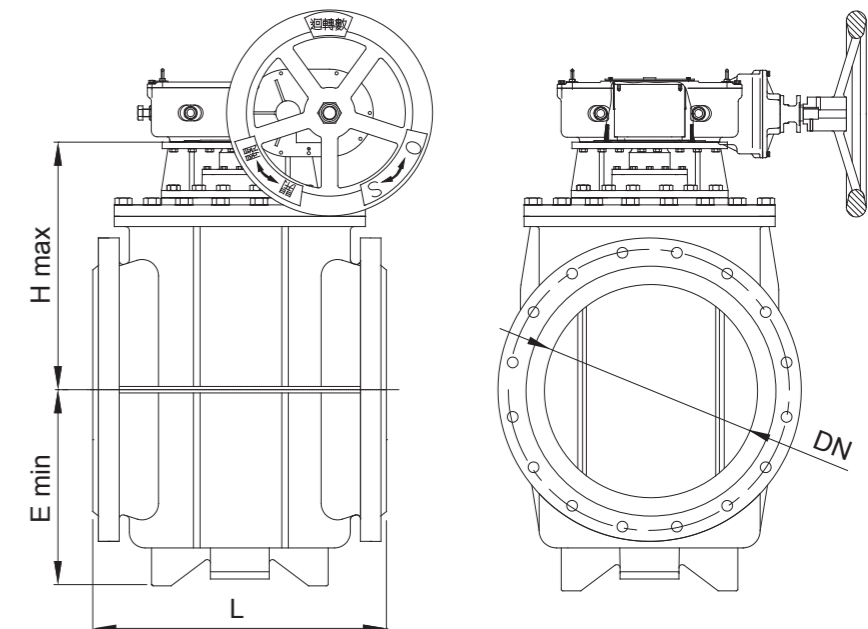

DIMENSION 尺寸表 unit : mm

SIZE DIM	80	100	125	150	200	250	300	350	400	450	500	600	700	800	900
L	203	229	229	267	292	330	356	406	406	620	620	700	800	900	1321
E (min)	100	120	120	140	150	180	200	400	400	450	530	300	600	600	700
H (max)	400	500	550	600	650	750	800	1300	1300	1450	1500	1550	1600	1600	1700

- NOTE: 1. Ø1000 ~ Ø1200 CAN BE MADE AS CUSTOMER'S REQUIREMENT.
2. WORM GEAR MODEL IS ACCORDING TO THE ACTUAL REQUIREMENT.
註: 1.可依客戶需求製作。
2.減速機型式可依實際需要配置。