



SK VALVES

Since 1966



SLEEVE CONTROL VALVES 套筒型(錐型)控制閥

Pressure Class & Flange / 壓力等級 & 法蘭規格				Fluid / 適用流體
Standard 規格	Class 等級	Operating Pressure 工作壓力	Flow 流速範圍	Clean Water 清水
ANSI	125	10 - 175 psi	Normal Service 常態流速 1.5 - 15 ft/sec 0.5 - 5 m/sec	Temperature Range / 流體溫度
	250	10 - 300 psi		0 - 80 ° C / 32 - 176 ° F (Liquid 液態)
ISO / DIN / BS	PN10	0.7 - 10 kgf/cm ²	Intermittent Service 容許瞬間流速 ft/sec m/sec	Testing Pressure / 測試壓力
	PN16	0.7 - 16 kgf/cm ²		According to ISO 5208 (Rate 3)
JIS / CNS	7.5 K	0.7 - 7.5 kgf/cm ²		SEAT / 閥座 : 1.1 × Max. Operating Pressure
	10.0 K	0.7 - 10 kgf/cm ²		BODY / 閥體 : 1.5 × Max. Operating Pressure
	16.0 K	0.7 - 16 kgf/cm ²		

OPTIONAL 其他配件

- 油壓動力單元
含驅動馬達、油壓泵浦、蓄壓器、油槽、控制單元
- 氣壓動力單元
含空壓機、蓄壓桶、控制單元
- 電動操作機
含驅動馬達、減速機、控制單元
- Oil driver power kit
Including motor, oil pump, pressure tank, oil tank, controller module
- Air driver power kit
Including air compressor, pressure tank, controller module
- Motor actuator
Including motor actuator, worm gear, controller module



Oil driver power kit
油壓動力單元



Program controller module
程序控制模組



Hydraulic controller module
水力型控制模組



- Multi- Nozzle Control Valve
多噴孔型 (4" ~ 104")
- Fixed- Cone Control Valve
單噴孔(固定錐)型 (4" ~ 104")

叶光閥業股份有限公司 SHYE KUANG VALVES MFG CO.,LTD.
恩盈企業股份有限公司 EN IN ENTERPRISE CO.,LTD.

■ 總公司 Headquarter
923屏東縣萬巒鄉佳興路83號 No. 83, Chia-Hsing Rd., Wan-Luan, Pingtung 923, Taiwan R.O.C.
TEL : +886-8-783-3834 FAX : +886-8-783-3734 Skype: skvalve.andrew
E-mail: international@skvalves.com.tw

■ 北區辦公室 North Taiwan Office
241新北市三重區環河北路三段270號1樓
No. 270, Sec. 3, Huanhe N. Rd., Sanchong Dist., New Taipei City 241076, Taiwan R.O.C.
TEL : +886-2-2988-4657 FAX : +886-2-2988-4657



www.skvalves.com.tw

■ 本公司對型錄所列之材質與尺寸保留認為必要時作修改之權利。或依客戶需求設計。實際尺寸及材質仍以客戶訂購時所提供之圖說為準。
SK Valves reserves the right to modify the materials or/and dimensions of the products as provided hereunder from time to time if necessary, or in accordance with the request of clients. The actual dimensions or/and material used are subject to the customer's request after placing the order.

PRODUCT DESCRIPTION 產品概說

The sleeve control valve adopts the design of axial flow channel, which enable the inner fluid of the channel to be controlled smoothly. Comparing with other control valves, the sleeve control valve produces less noise and has less cavitation. In addition, the coefficient Cv of the flow rate and stroke are almost in linear relation, which means that this kind of valves can achieve precision flow control.

套筒型(錐型)控制閥採軸流式流道設計,使流道內的流體能平順的被控制,相較於其他控制閥有更小的噪音及穴蝕現象,且閥之流量係數Cv與行程幾乎呈線性關係,以達成精確控制之目的。

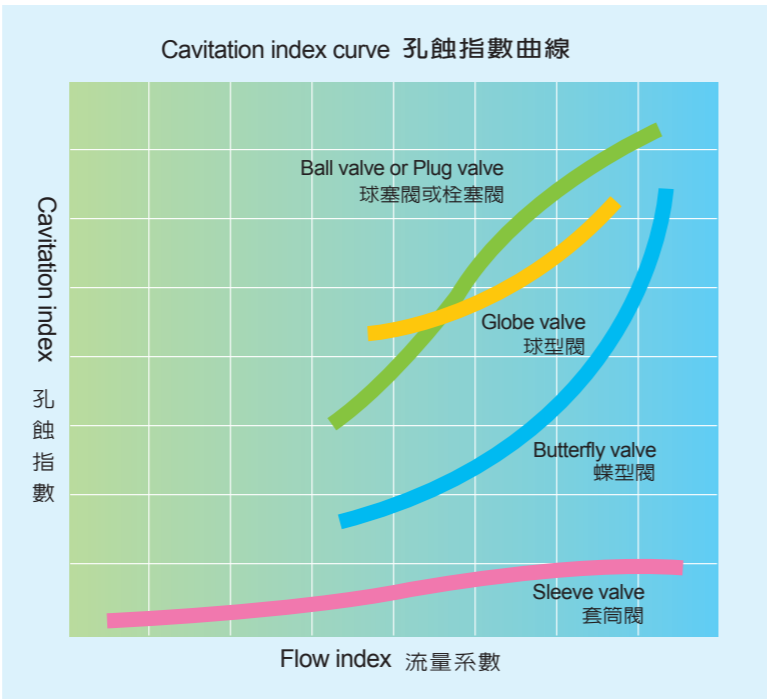

(The customized 客製化)

STROKE & Cv CURVE 閥行程與流量係數曲線圖

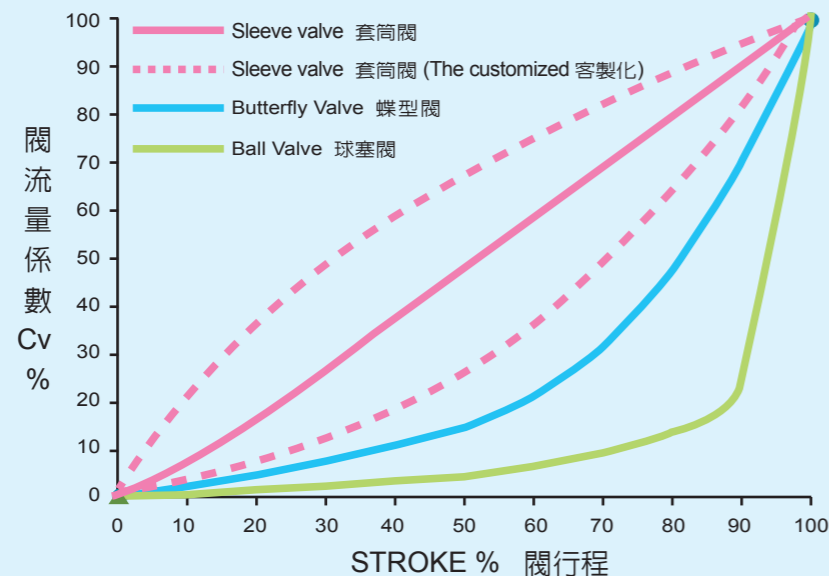

The sleeve control valve can be categorized respectively into MULTI-JET CONTROL VALVE and FIXED CONE CONTROL VALVE, based on different channel and layout designs.

套筒型(錐型)控制閥依流道設計及配置不同又分為多噴孔控制閥及單噴孔(固定錐型)控制閥。

Characteristic comparison 特性比較

Comparison 特性類別	Multi-Jet control valve 多噴孔控制閥	Fixed-Cone control valve 單噴孔(固定錐)控制閥
Control curve 控制曲線	Linear / customized 線性 / 客製化	Linear 線性
Energy dissipation capability 消能能力	Excellent 極佳	Good 好
Fluid 適用流體	Clean water 清水	Clean water, raw water and sewage 清水、原水、汙水

GENERAL PRODUCT DESCRIPTIONS 產品功能概要

The categories of control valve 控制閥型式	Control system 控制系統	Description 主要功能說明
SSH-RL Fixed Cone pressure relief valve SSH-RL固定錐型持(洩)壓閥	<ul style="list-style-type: none"> 操作機: (四選一) 水壓缸 / 油壓缸 / 氣油壓缸 / 電動操作機 現場控制箱 控制系統: (配合設計功能) 壓力偵測模組 電磁閥組 PLC可程式控制器 Actuator(one of four options) water cylinder . oil cylinder pneumatic w/oil cylinder motor actuator remote control box Control system Pressure sensor mode Solenoid model PLC 	<p>維持上游管線系統於設定壓力之下。當控制閥上游壓力大於設定壓力時,錐型閥自動增加套筒開度並維持調節狀態。</p> <p>Maintaining the pressure of pipeline at the upstream within the setting of pressure index.If the pressure of the pipeline at upstream is higher than the setting index, the valve will automatically adjust its stroke to release the pressure.</p>
SSR-RD Fixed Cone pressure reducing valve SME-RD Multi-Jet pressure reducing valve SSH-RD固定錐型減壓閥 SME-RD多噴孔型減壓閥	<ul style="list-style-type: none"> 操作機: (四選一) 水壓缸 / 油壓缸 / 氣油壓缸 / 電動操作機 現場控制箱 控制系統: (配合設計功能) 減壓嚮導閥 電磁閥組 PLC可程式控制器 Actuator(one of four options) water cylinder . oil cylinder pneumatic w/oil cylinder motor actuator remote control box Control system Pressure sensor mode Solenoid model PLC 	<p>維持下游管線系統於設定壓力之下,當控制閥下游壓力大於設定壓力時,錐型閥自動減少套筒開度並維持調節狀態。</p> <p>Maintaining the pressure of pipeline at the downstream within the setting of pressure index.If the pressure of the pipeline at downstream is higher than the setting index, the valve will automatically adjust its stroke of cage to control the pressure thereof.</p>
SSH-FW Fixed Cone valveRate of flow valve SME-FW Multi-Jet valveRate of flow valve SSH-FW固定錐型流量控制閥 SME-FW多噴孔型流量控制閥	<ul style="list-style-type: none"> 操作機: (四選一) 水壓缸 / 油壓缸 / 氣油壓缸 / 電動操作機 現場控制箱 控制系統: (配合設計功能) 流量嚮導閥 電磁閥組 PLC可程式控制器 流量偵測器 Actuator(one of four options) water cylinder . oil cylinder pneumatic w/oil cylinder motor actuator remote control box Control system Pressure sensor mode Solenoid model PLC Flow sensor 	<p>控制管線流量於設定之範圍內。當流量低於或高於設定值時,錐型閥自動增加或減少套筒開度並維持調節狀態。</p> <p>Setting range.The valve will automatically adjust the stroke of cage to control the rate of flow, if it is either higher or lower than the setting index.</p>

Remark 備註

- Working pressure of hydraulic cylinder shall be at minimum of 1kgf/cm². Otherwise, extra water pressure supply is required.
- Customization is available for pressure level and flange specification not provided under this catalog.

- 水力操作(水壓缸)系統因採用管線自有水壓,因此工作壓力至少需達 1 kgf/cm²,否則須另提供外部水壓來源
- 其它壓力等級及法蘭規格可另行設計

Multi- Nozzle Control Valve 多噴孔控制閥

PRINCIPLE OF MOVEMENT 作動原理

The channel of sleeve valve adopts the concept of axial flow/ vertical flow design. With a movable sleeve gate at the exterior of the multi-nozzle sleeve, it can control the quantity of the multi-nozzle subject to different scenarios. The interior sleeve with multi-nuzzle structure can form the fluid therein into high-speed water jets and lead those water jets to impact with each other to eliminate the energy occurred by the flow. This can effectively prevent the inner wall of the valve from the damages of vibration, noise, and erosion effect.

此閥整體流道採軸流式或豎立式設計，流體經由一組由多個噴孔所形成的噴孔管，引導流體形成高速水柱在噴孔管內部相互衝擊，藉以消除能量，噴孔管外部配置一可移動之套筒，並藉此套筒之行程位置控制有效噴孔數量，同時因為整個消能撞擊過程都在消能管內部完成，因此可有效降低震動、噪音及避免沖蝕現象直接作用於閥體內壁，藉以延長主閥使用壽命。

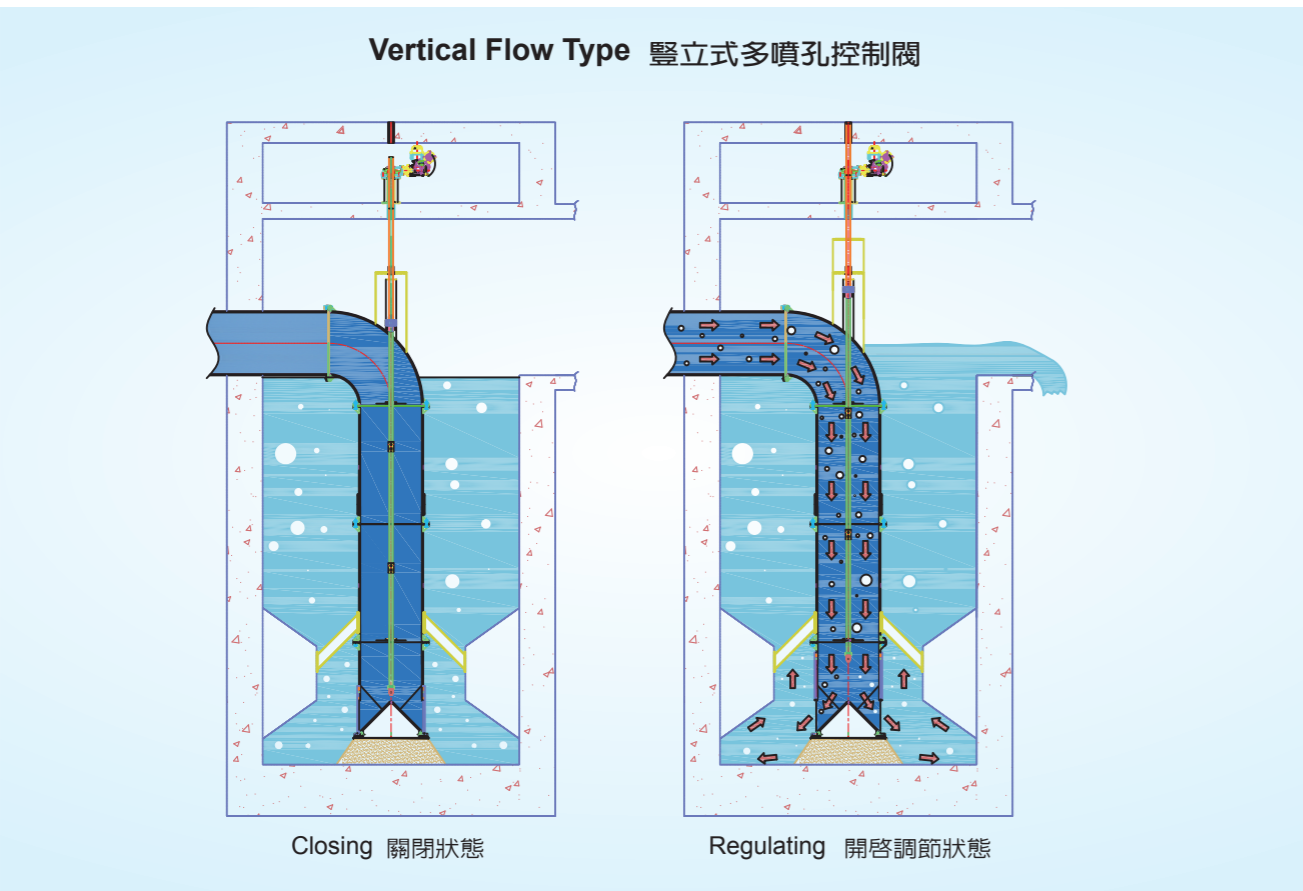
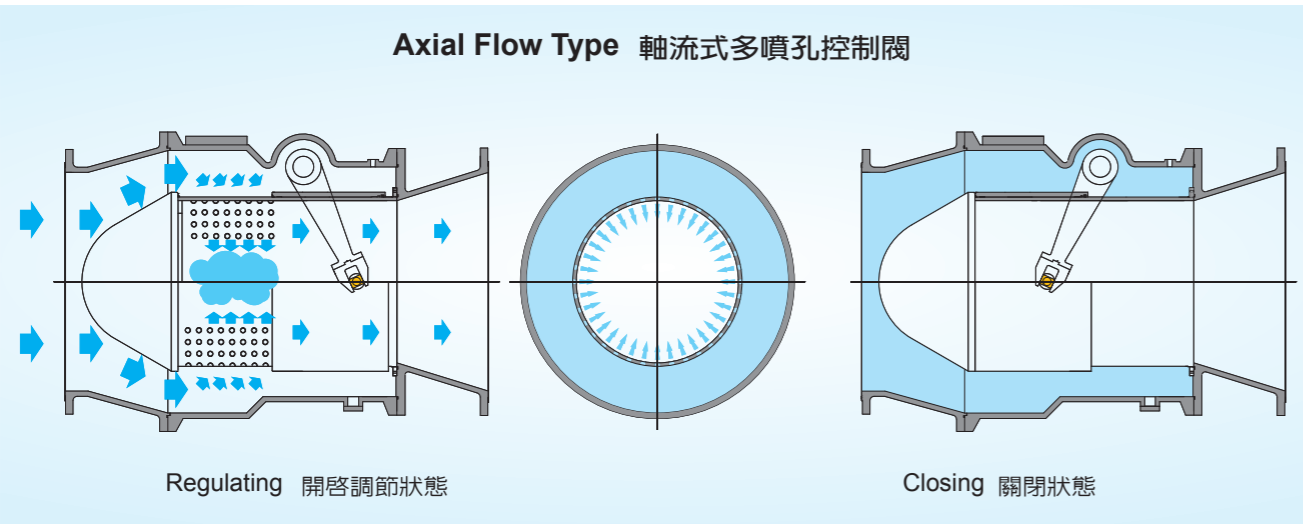

FEATURES OF DESIGN 設計特點

● The customized design of multi-nozzle

The multi-nozzles are designed in the pattern of spiral distribution which can avert any ineffective stroke. The pore size and the number of the pore of the multi-sleeve can be customized pursuant to the hydraulic analysis provided by the customers.

● 客製化螺旋型配置噴孔設計

噴孔孔徑及孔數可依客戶水理分析作最佳配置，且所有噴孔採螺旋式配置以確保控制的連續性。

● Advanced tapered nozzle design

The tapered nozzles allow the flow to enter the sleeve smoothly and quickly. With this design the flow can be precisely controlled and the energy through the sleeve can also dissipated.

● 先進錐狀噴孔設計

錐狀型噴孔使水流平順加速成噴流進入噴孔管中，除可以精確控制流量外，又可藉噴流對撞達成消能目的。

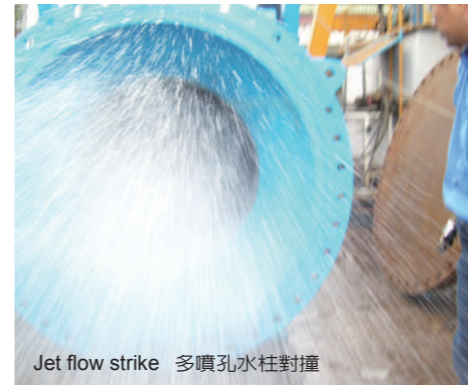

Structure & Material 構造材質

- 1. Body 閥體:
Ductile Cast Iron 球墨鑄鐵
Stainless Steel 不鏽鋼
Carbon Steel 碳鋼
- 2. Seat 閥座:
EPDM
Neoprene 合成橡膠
ALBC 鋁青銅
- 3. Sleeve 多噴孔管:
Stainless Steel 不鏽鋼
- 4. Gate 套筒閘:
Stainless Steel 不鏽鋼
Nitronic
- 5. Shaft 閥軸:
Stainless Steel 不鏽鋼
- 6. Drive Arm 驅動臂:
Ductile Cast Iron 球墨鑄鐵

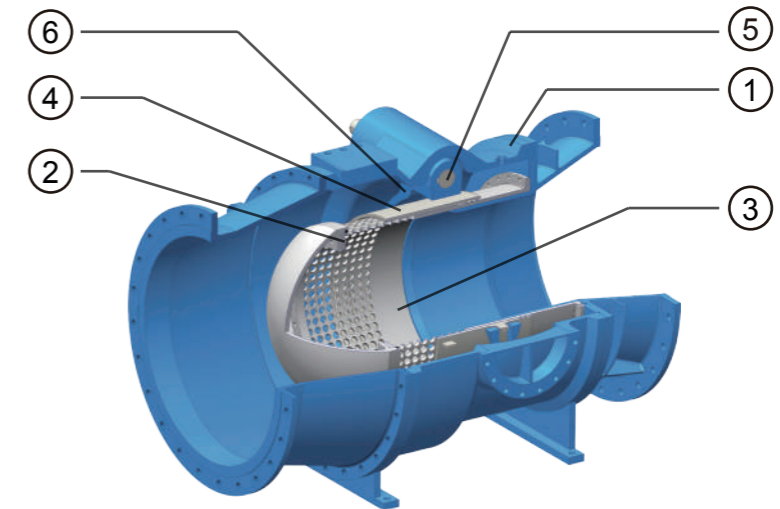

Multi-jet Control Valve Sectional View
多噴孔剖面圖



ACTUATION PRINCIPLE 作動原理

The entire channel of fixed-cone control valve adopts the axial flow design. Through a specially designed fixed-cone structure and splitter which enable the valve to form the fluid therein into annular flow, and by the movable sleeve which can control the opening of the stroke, it can effectively reduce the damages of vibration, noise, and cavitation occurred when the fluid flow through the splitter and dissipation tube. The pressure head is extremely low when the valve is fully open. This can be used as discharge valve for the end of the pipeline or flow control valve at the pipeline.

此閥整體流道採軸流式設計，由一特殊設計之固定錐型體及導流片引導流體成環狀分流，導流片上之滑軌支撐一可移動之套筒，並藉此套筒之行程位置控制開口開度，流體經過特殊設計之消能管及導流片可有效降低震動、噪音及避免沖蝕現象直接作用於閥體內壁。開時其水頭損失極低，可作管末端放流控制閥或管線中流量控制閥使用。

Discharge Type 放流式單噴孔控制閥

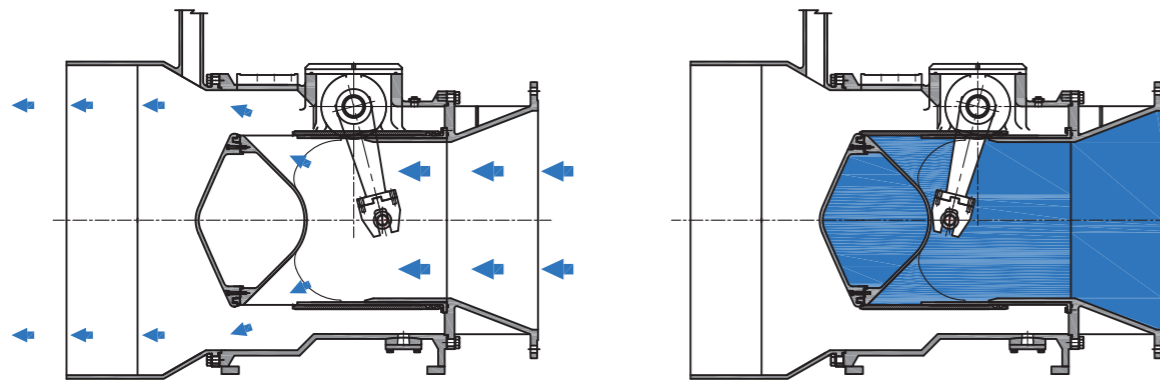

Discharging 放流狀態

Closing 關閉狀態

Axial Flow Type 軸流式單噴孔控制閥

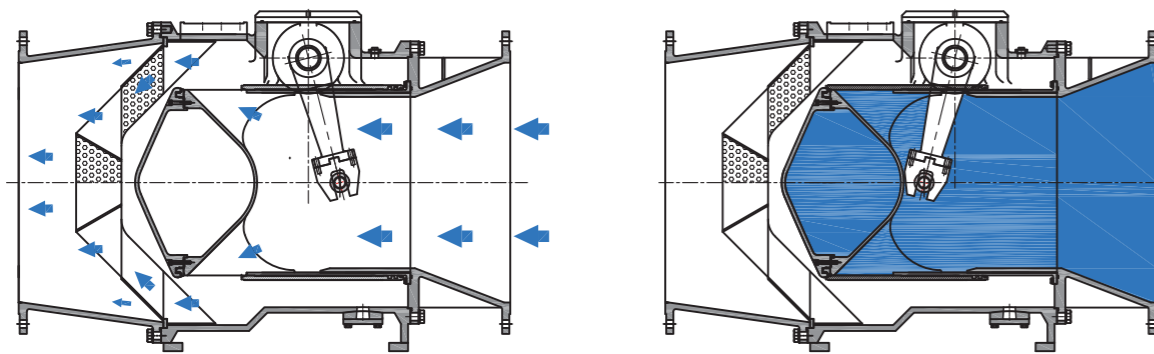

Regulating 開啓調節狀態

Closing 關閉狀態

FEATURES OF DESIGN 設計特點

- **Self-adjusting seat**
The metal to metal (valve) seat ensures the function of watertight and extend the lifetime of the valve seat.
- **Fixed cone design**
The annular diversion tunnel design can reduce cavitation effect.
- **Energy dissipation design**
The energy dissipation fitting can reduce the vibration and cavitation occurring on the inner wall of the valve body.

- **浮動閥座設計**
金屬-金屬閥座 標準化設計沒有橡膠老化或破損之虞，可延長使用壽命。
- **固定錐型設計**
特殊環狀分流流道設計減少穴蝕現象產生。
- **消能管設計**
特殊消能管可有效降低震動及穴蝕現象作用於閥體上。

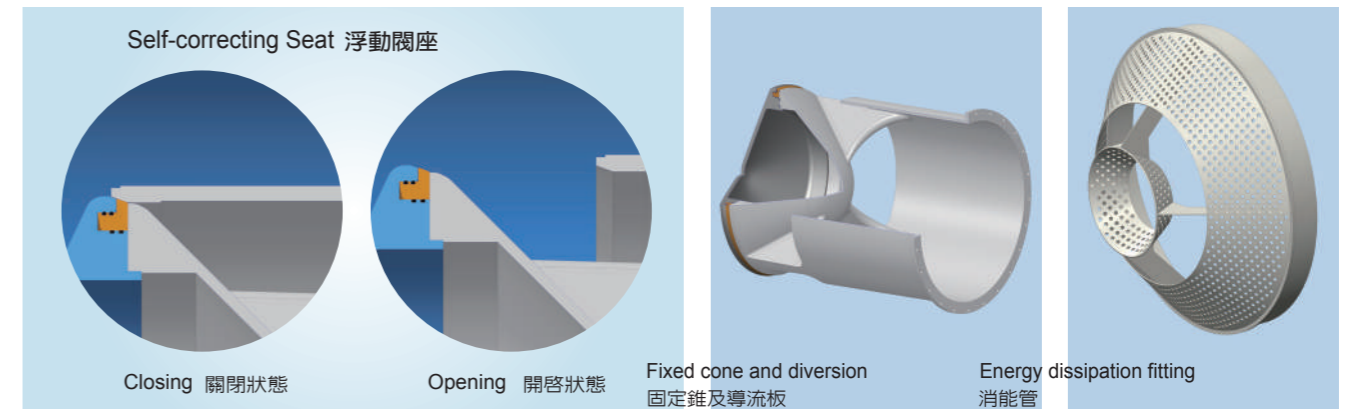

Structure & Material 構造材質

1. Body 閥體:
Ductile Cast Iron 球墨鑄鐵
Stainless Steel 不鏽鋼
Carbon Steel 碳鋼
2. Seat 閥座:
ALBC 鋁青銅
3. Sleeve 單噴孔管:
Stainless Steel 不鏽鋼
4. Fixed Cone 固定錐:
Stainless Steel 不鏽鋼
Ductile Cast Iron 球墨鑄鐵
5. Gate 套筒閘:
Stainless Steel 不鏽鋼
Nitronic
6. Shaft 閥軸:
Stainless Steel 不鏽鋼
7. Drive Arm 驅動臂:
Ductile Cast Iron 球墨鑄鐵
8. Energy dissipation fitting 消能管:
Stainless Steel 不鏽鋼

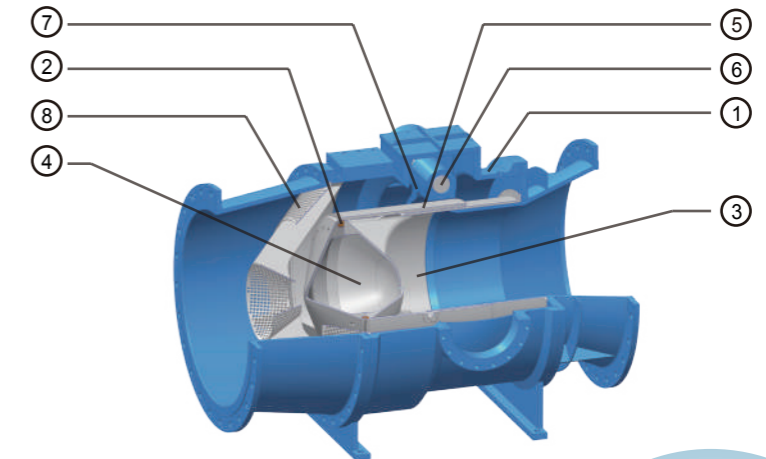

Sectional View 單噴孔剖面圖

