



Since 1966

SK VALVES

AIR RELEASE VALVES 排氣閥



Air / Vacuum Valve ■
排/吸氣閥 $\Phi 200\sim\Phi 400\text{mm}$
(8" ~ 16")

Automatic Air Valve ■
自動釋氣閥 $\Phi 13\sim\Phi 50\text{mm}$
(1/2" ~ 2")

Combination Air Valve ■
複合式排氣閥 $\Phi 20\sim\Phi 400\text{mm}$
(3/4" ~ 16")

Quick Air Valve ■
急速式排氣閥 $\Phi 20\sim\Phi 300\text{mm}$
(3/4" ~ 12")

Sewage Air Valve ■
污水用排氣閥 $\Phi 20\sim\Phi 200\text{mm}$
(3/4" ~ 8")

Surge Valve ■
突波緩衝塞閥 $\Phi 50\sim\Phi 400\text{mm}$
(2" ~ 16")

叶光閥業股份有限公司 SHYE KUANG VALVES MFG CO.,LTD.
恩盈企業股份有限公司 EN IN ENTERPRISE CO.,LTD.

■ 總公司 Headquarter
923屏東縣萬巒鄉佳興路83號 No. 83, Chia-Hsing Rd., Wan-Luan, Pingtung 923, Taiwan R.O.C.
TEL : +886-8-783-3834 FAX : +886-8-783-3734 Skype: skvalve.andrew
E-mail: international@skvalves.com.tw

■ 北區辦公室 North Taiwan Office
241新北市三重區環河北路三段270號1樓
No. 270, Sec. 3, Huanhe N. Rd., Sanchong Dist., New Taipei City 241076, Taiwan R.O.C.
TEL : +886-2-2988-4657 FAX : +886-2-2988-4657



www.skvalves.com.tw

■ 本公司對型錄所列之材質與尺寸保留認為必要時作修改之權利，或依客戶需求設計，實際尺寸及材質仍以客戶訂購時所提供之圖說為準。
SK Valves reserves the right to modify the materials or/and dimensions of the products as provided hereunder from time to time if necessary, or in accordance with the request of clients. The actual dimensions or/and material used are subject to the customer's request after placing the order.

PRODUCT DESCRIPTION 產品概說

系列 Series	適性說明 Description
Air / Vacuum Valve 排/吸氣閥	While filling/ draining the pipeline, combination air valves allow a large amount of air to escape/inject into the system 空管進水時大量排氣及停水時吸入空氣避免真空破管
Automatic Air Valve 自動釋氣閥	exhausting air while the fluid is transported in the pipeline to prevent accruing air pockets affecting the transporting efficiency 可釋放管中微小氣泡避免氣囊產生，增加輸水效率
Combination Air Valve 複合式排氣閥	Combination of Air/Vacuum Valve and Automatic Air Valve 兼具排/吸氣閥、自動釋氣閥之功能
Quick Air Valve 急速式排氣閥	Applicable at the pump outlet and the end of the pipeline 適合裝置於泵浦出水端及管線末端
Sewage Air Valve 污水用複合式排氣閥	Applicable for sewage, raw water, and wastewater 適用汙水、原水、廢水

LOCATION OF AIR VALVES 配置建議圖

- Improve the water flow performance.
提高泵浦使用效率和提高管線送水效率。
- Injecting air into the pipeline to prevent collapse due to vacuum
當泵浦停止作動時，能吸入空氣維持管內壓力避免管線產生之負壓損壞管線。
- Generally, the air valves are suggested to install at the system's high points, where air pockets are most likely to accumulate.
管線最高處及局部高處，空氣易累積處。

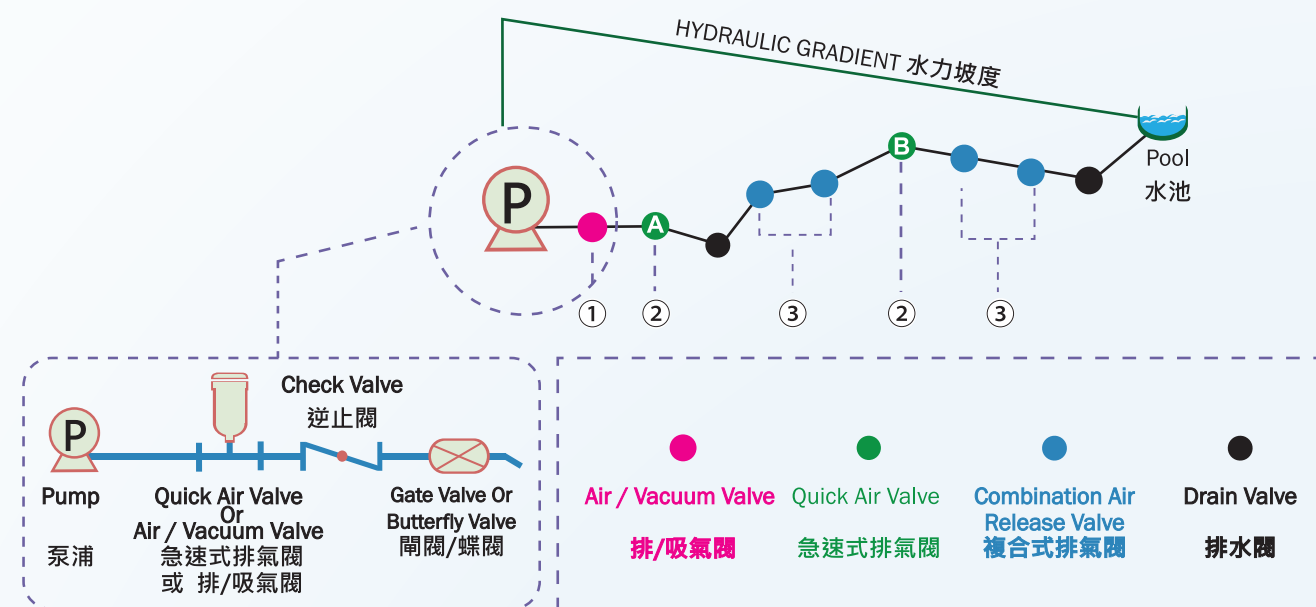

- ① Installed in between pump and check valve to manage the air entering/escaping the line so as the pressure within.
- ② A & B: Combination Air Valve and Quick Air Valve can be used on these two points
- ③ It is recommended to leave 500-1000 meters between air valves.

裝置於泵浦和逆止閥之間，當泵浦啟動時可以排除管內空氣，當泵浦關閉時可以吸入空氣避免管內產生負壓。

排氣閥裝設時所需要之間隔距離為 500-1000m。

A與B兩處可用複合式或急速式排氣閥。

AIR VALVE PRINCIPLE MOVEMENT 排/吸氣閥作動原理

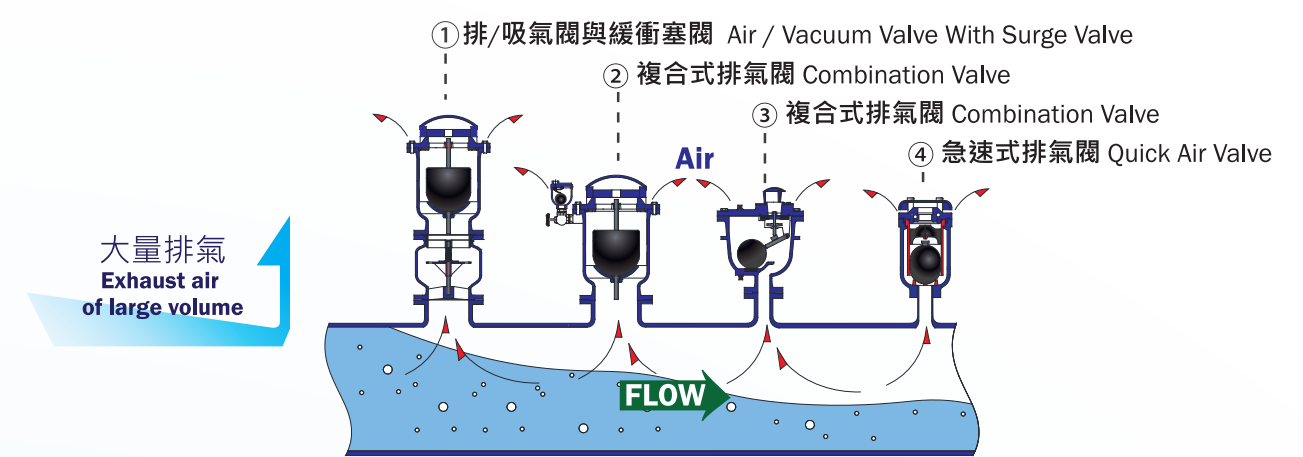

While the pipeline is filling with fluid, air valves allow air to escape to prevent the flow performance from affecting by the excess air within the pipeline. Once the fluid fully contains the pipeline, the float ball in the air valves will be pushed upward to put the plug back in the closing position, which can prevent the liquid from spilling out.

當管線開始進水時，管內空氣由排氣閥大排氣口排出，提高管線輸送水效率。當管中充滿水時，排氣閥中之浮球浮起，帶動塞頭關閉排氣口，防止管中水流洩出。

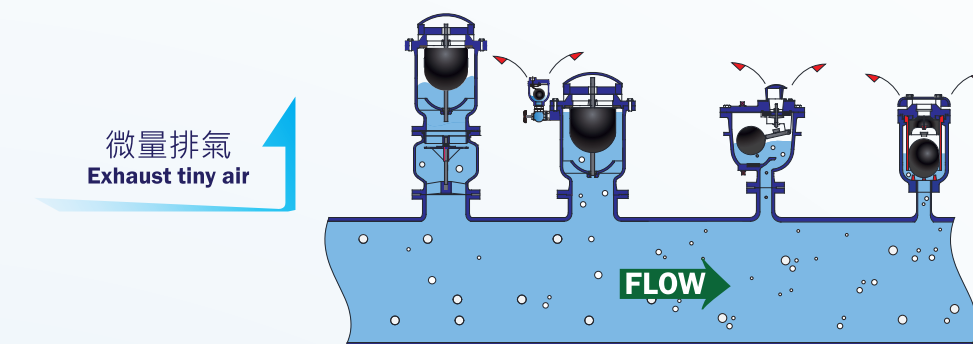

Air pockets accumulate along fluid transport and gather at high points along the pipelines. As long as the air valves are installed at adequate positions, air bubbles can be trapped in the air valves. When a certain amount of air is reached, the float ball will drop by a bit to keep the plug in the closing position while letting the air escape through an orifice at the bottom of the plug. Once this process is done, the float ball will return to its original position to keep the orifice closed.

管線輸送水的過程中，仍會累積少量空氣於排氣閥內，當累積到一定程度時，排氣閥中之浮球下降(此時塞頭因管內壓力能停在關閉位置)，空氣由塞頭下方之小孔排出後，浮球隨即浮起塞住小孔。

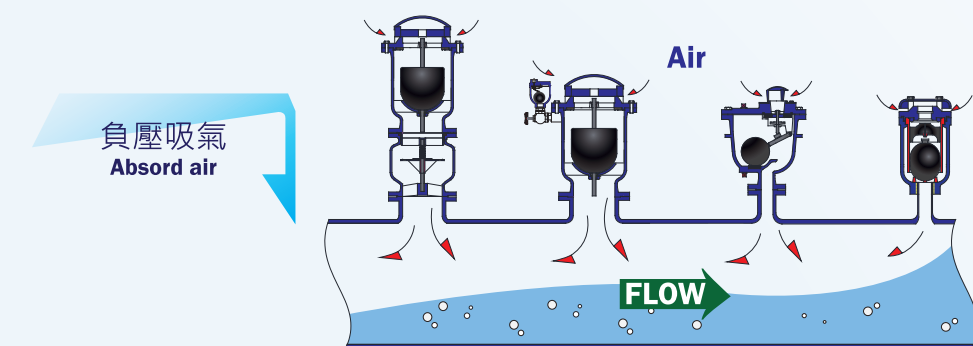

When the pump stops, a vacuum can occur within the pipeline and cause pipeline collapse; to accommodate this problem, air valves can open the plug promptly and allow air to fill the pipeline.

當管內停止進水時，管線可能因使產生負壓，此時塞頭能迅速開啟，讓管線吸入空氣，避免管線破裂。

FEATURES 設計特點

- While the pipeline is being filled, air/vacuum valves allow a large amount of air to escape.
當空管進水時，排/吸氣閥能大量排氣。
- water outage, air/vacuum valves allow a large amount of air to fill in to prevent pipeline collapse caused by vacuum.
當管線停水時排/吸氣閥能及時吸入空氣，防止管線因真空現象造成破裂。

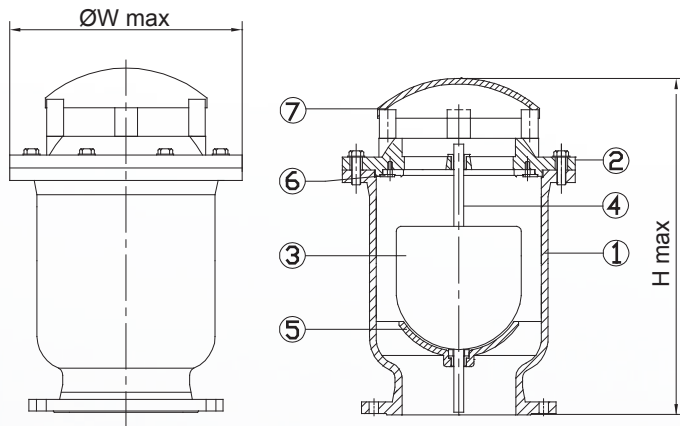

DN200-400

DIMENSION 尺寸表

DIM. SIZE	ΦW max	H max
200	550	640
250	650	770
300	800	970
400	900	1150

功能曲線圖 CHARACTERISTIC CURVE

NOTE: SHADED AREAS INDICATE NON STANDARD OPTIONS
註:標示口徑的曲線為參考值。

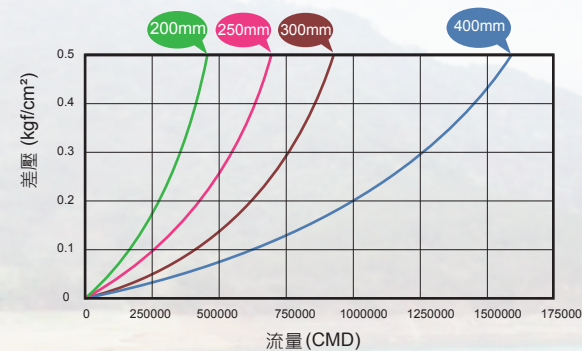

FEATURES 設計特點

- The automatic air valve is designed to be installed at the highest point of the pipeline system, which can release the accumulated air under any working pressure.
設於管線至高點，任何工作壓力下能排出累積空氣。
- Preventing fluid spilled out under pressure less than 0.2kg/cm².
壓力低於0.2kg/cm² 也可防止水流溢出。
- Small in size, easy to maintain.
體積小，維護容易。



DN25



DN50

功能曲線圖 CHARACTERISTIC CURVE

NOTE: SHADED AREAS INDICATE NON STANDARD OPTIONS
註:標示口徑的曲線為參考值。

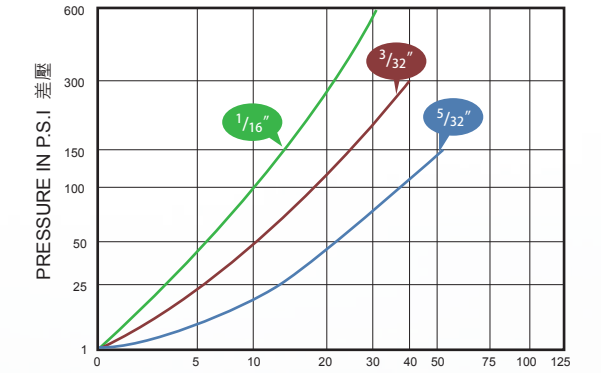

DISCHARGE OF AIR THROUGH AN ORIFICE IN S.C.F.M.
(STANDARD CUBIC FEET OF FREE AIR PER MINUTE)
排氣量

Choice suitable orifice by "characteristic curve"
依功能曲線圖選擇需要的排氣孔口

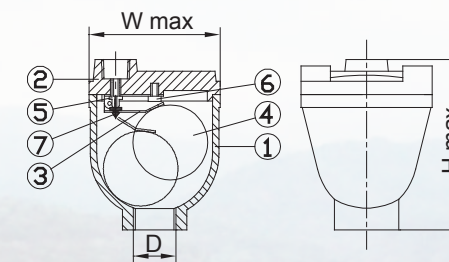

DN25 DIMENSION 尺寸表

DIM. SIZE	D	W max	H max
13~25	1/2"~1"	200	340

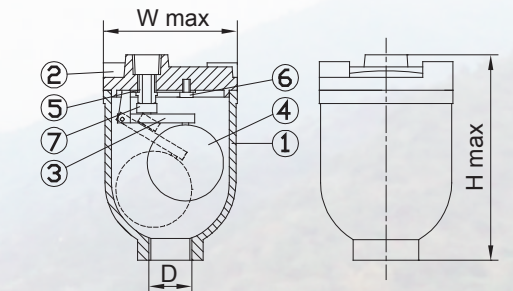

DN50 DIMENSION 尺寸表

DIM. SIZE	D	W max	H max
32~50	1 1/4"~2"	215	360

PARTS & MATERIAL 零件材質表

NO.	PARTS 零件	MATERIAL 材質
1.	Body 閥體	DUCTILE CAST IRON 球墨鑄鐵 / SCS 鑄不銹鋼 / ALBC 鋁青銅
2.	Cover 上閥蓋	DUCTILE CAST IRON 球墨鑄鐵 / SCS 鑄不銹鋼 / ALBC 鋁青銅
3.	Float Ball 浮球	STAINLESS STEEL 不銹鋼
4.	Axis 浮桿	STAINLESS STEEL 不銹鋼
5.	Float Base 浮球座	SCS 鑄不銹鋼 / ALBC 鋁青銅
6.	Seat 座封	NBR / EPDM / VITON 合成橡膠
7.	Vent Cap 排氣口蓋	DUCTILE CAST IRON 球墨鑄鐵 / SCS 鑄不銹鋼 / ALBC 鋁青銅

PARTS & MATERIAL 零件材質表

NO.	PARTS 零件	MATERIAL 材質
1.	Body 閥體	DUCTILE CAST IRON 球墨鑄鐵 / SCS 鑄不銹鋼 / ALBC 鋁青銅
2.	Cover 上閥蓋	DUCTILE CAST IRON 球墨鑄鐵 / SCS 鑄不銹鋼 / ALBC 鋁青銅
3.	Lever 槓桿	STAINLESS STEEL 不銹鋼
4.	Float Ball 浮球	STAINLESS STEEL 不銹鋼
5.	Plug 塞頭	STAINLESS STEEL 不銹鋼 / BRONZE 青銅
6.	Bolt 螺栓	STAINLESS STEEL 不銹鋼
7.	Seat 座封	NBR / EPDM / VITON 合成橡膠

FEATURES 設計特點

- Combination Air Valve is designed to be installed at the highest point of the pipeline/ section of the channel.
複合式排氣閥常裝設於送配水管線中或管線局部高處。
- While the pipeline is being filled/ drained, combination air valves allow a large amount of air to be exhausted /admitted into the system.
複合式排氣在空氣管進水初期能大量排出管中空氣，也能在管線停水時吸入空氣，避免負壓。
- During the fluid transporting in a fully contained pipeline, it can release accumulated air through the plug to prevent accruing air pockets from affecting the water flow performance.
滿管送水時，能透過塞頭之小孔排出管中累積之微小空氣，避免管線形成氣囊，影響輸水效率。

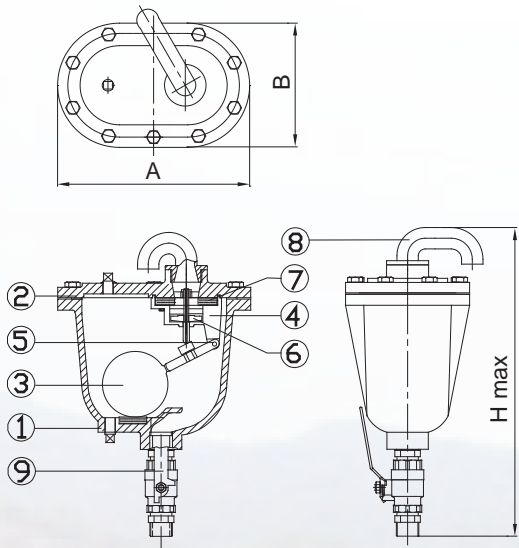

DN20-25 DIMENSION 尺寸表

DIM. SIZE	A	B	H
			max
20	280	180	460
25	280	180	480



功能曲線圖 CHARACTERISTIC CURVE

NOTE: SHADED AREAS INDICATE NON STANDARD OPTIONS
註:標示口徑的曲線為參考值。

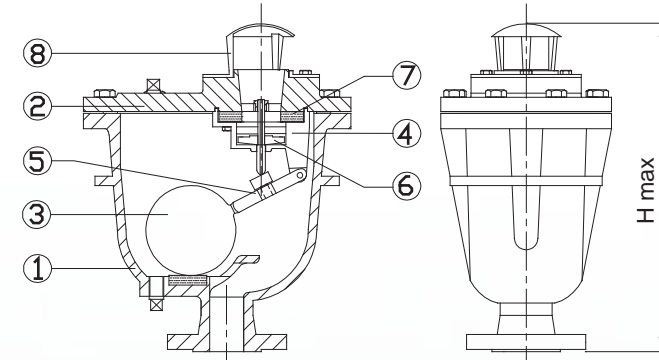
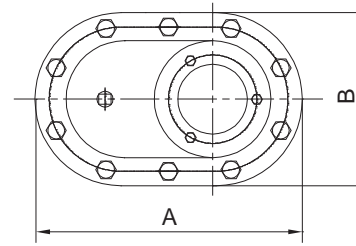
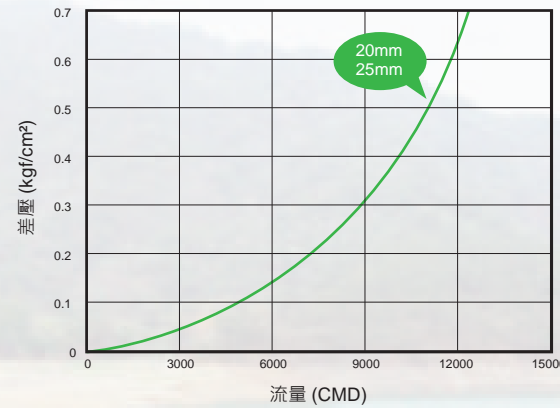

功能曲線圖 CHARACTERISTIC CURVE

NOTE: SHADED AREAS INDICATE NON STANDARD OPTIONS
註:標示口徑的曲線為參考值。

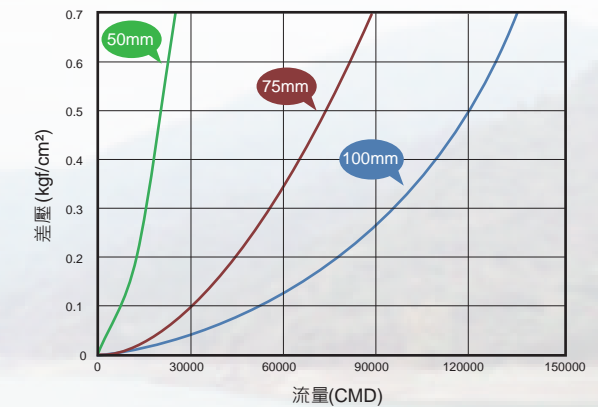

DN50-100 DIMENSION 尺寸表

DIM. SIZE	A	B	H
			max
50	340	225	480
75	380	250	540
100	400	280	650

PARTS & MATERIAL 零件材質表

NO.	PARTS 零件	MATERIAL 材質
1.	Body 閥體	DUCTILE CAST IRON 球墨鑄鐵 / SCS 鑄不銹鋼 / ALBC 鋁青銅
2.	Cover 上閥蓋	DUCTILE CAST IRON 球墨鑄鐵 / SCS 鑄不銹鋼 / ALBC 鋁青銅
3.	Float Ball 浮球	STAINLESS STEEL 不銹鋼
4.	Lever Frame 槓桿架	DUCTILE CAST IRON 球墨鑄鐵 / SCS 鑄不銹鋼 / ALBC 鋁青銅
5.	Lever 槓桿	STAINLESS STEEL 不銹鋼
6.	Plug 塞頭	STAINLESS STEEL 不銹鋼 / BRONZE 青銅
7.	Seat 座封	NBR / EPDM / VITON 合成橡膠
8.	Exhaust Knee 排氣彎管	DUCTILE CAST IRON 球墨鑄鐵 / SCS 鑄不銹鋼 / ALBC 鋁青銅
9.	Cock 考克	STAINLESS STEEL 不銹鋼 / BRONZE 青銅

PARTS & MATERIAL 零件材質表

NO.	PARTS 零件	MATERIAL 材質
1.	Body 閥體	DUCTILE CAST IRON 球墨鑄鐵 / SCS 鑄不銹鋼 / ALBC 鋁青銅
2.	Cover 上閥蓋	DUCTILE CAST IRON 球墨鑄鐵 / SCS 鑄不銹鋼 / ALBC 鋁青銅
3.	Float Ball 浮球	STAINLESS STEEL 不銹鋼
4.	Lever Frame 槓桿架	DUCTILE CAST IRON 球墨鑄鐵 / SCS 鑄不銹鋼 / ALBC 鋁青銅
5.	Lever 槓桿	STAINLESS STEEL 不銹鋼
6.	Plug 塞頭	STAINLESS STEEL 不銹鋼 / BRONZE 青銅
7.	Seat 座封	NBR / EPDM / VITON 合成橡膠
8.	Vent Cap 排氣口蓋	DUCTILE CAST IRON 球墨鑄鐵 / SCS 鑄不銹鋼 / ALBC 鋁青銅

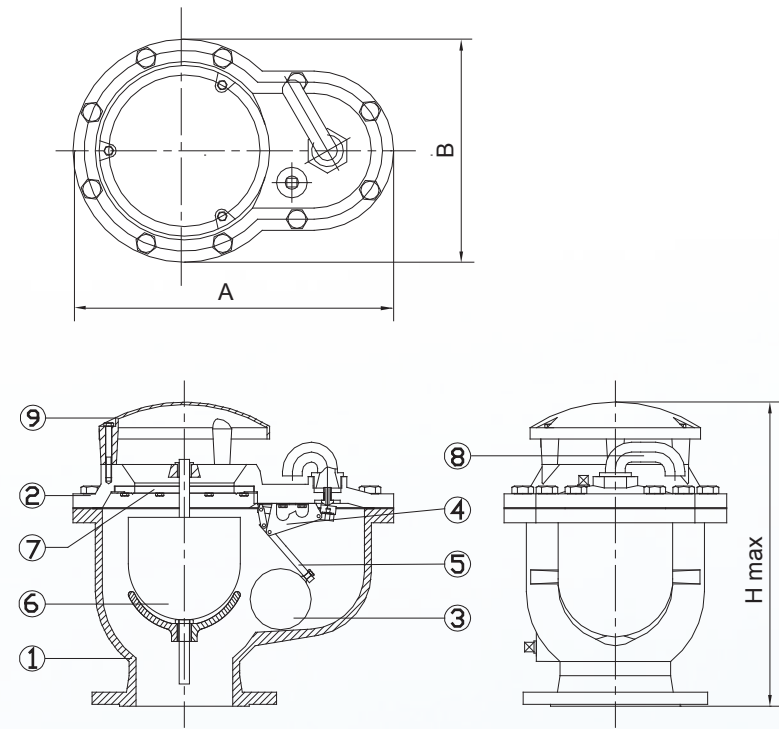

功能曲線圖 CHARACTERISTIC CURVE

NOTE: SHADED AREAS INDICATE NON STANDARD OPTIONS
註: 標示口徑的曲線為參考值。

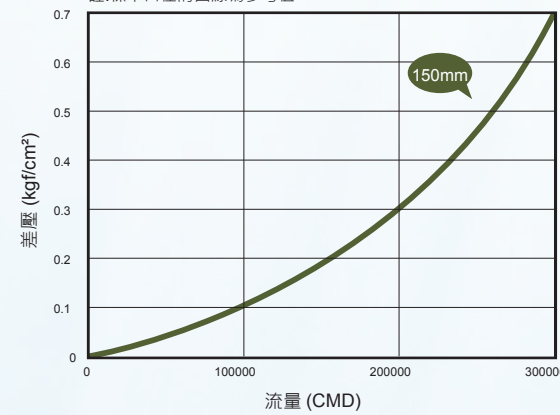

DN150 DIMENSION 尺寸表

DIM. SIZE	A	B	H max
150	550	350	570

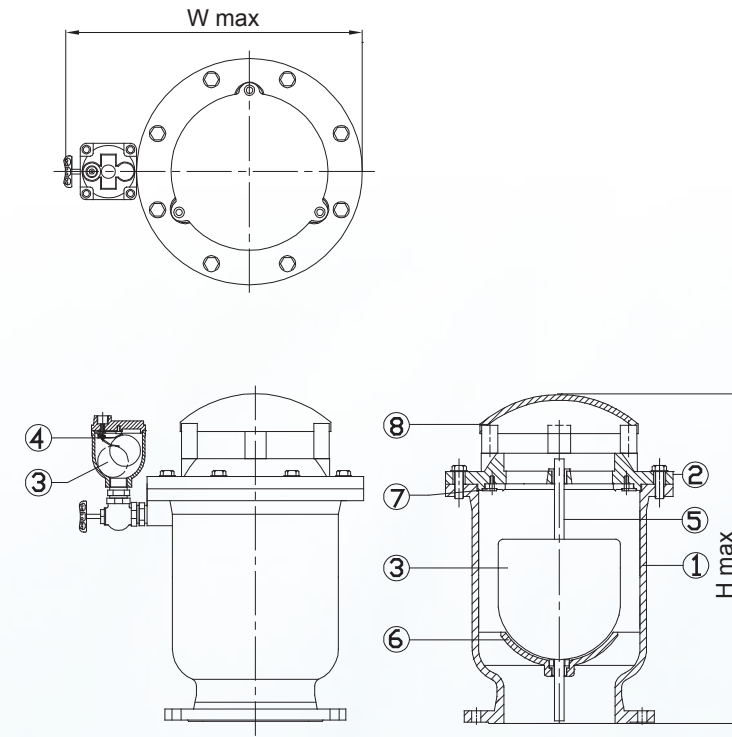

功能曲線圖 CHARACTERISTIC CURVE

NOTE: SHADED AREAS INDICATE NON STANDARD OPTIONS
註: 標示口徑的曲線為參考值。

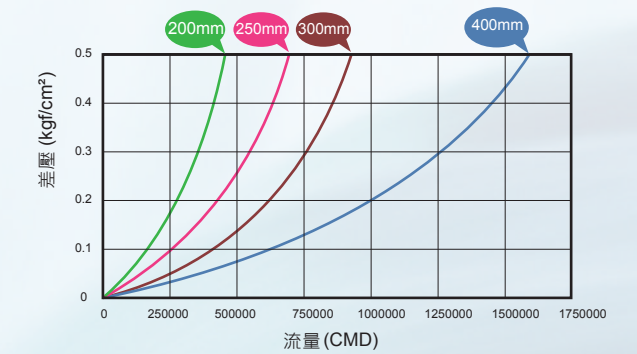

DN200-400 DIMENSION 尺寸表

DIM. SIZE	W max	H max
200	570	640
250	680	770
300	830	970
400	930	1150

PARTS & MATERIAL 零件材質表

NO.	PARTS 零件	MATERIAL 材質
1.	Body 閥體	DUCTILE CAST IRON 球墨鑄鐵 / SCS 鑄不銹鋼 / ALBC 鋁青銅
2.	Cover 上閥蓋	DUCTILE CAST IRON 球墨鑄鐵 / SCS 鑄不銹鋼 / ALBC 鋁青銅
3.	Float Ball 浮球	STAINLESS STEEL 不銹鋼
4.	Lever Frame 槓桿架	STAINLESS STEEL 不銹鋼
5.	Lever 槓桿	STAINLESS STEEL 不銹鋼
6.	Plug Ball 浮球塞頭	STAINLESS STEEL 不銹鋼
7.	Seat 座封	NBR / EPDM / VITON 合成橡膠
8.	Exhaust Knee 排氣彎管	DUCTILE CAST IRON 球墨鑄鐵 / SCS 鑄不銹鋼 / ALBC 鋁青銅
9.	Vent Cap 排氣口蓋	DUCTILE CAST IRON 球墨鑄鐵 / SCS 鑄不銹鋼 / ALBC 鋁青銅

PARTS & MATERIAL 零件材質表

NO.	PARTS 零件	MATERIAL 材質
1.	Body 閥體	DUCTILE CAST IRON 球墨鑄鐵 / SCS 鑄不銹鋼 / ALBC 鋁青銅
2.	Cover 上閥蓋	DUCTILE CAST IRON 球墨鑄鐵 / SCS 鑄不銹鋼 / ALBC 鋁青銅
3.	Plug Ball 浮球塞頭	STAINLESS STEEL 不銹鋼
4.	Lever Frame 槓桿架	STAINLESS STEEL 不銹鋼
5.	Axis 浮桿	STAINLESS STEEL 不銹鋼
6.	Float Base 浮球座	SCS 鑄不銹鋼 / ALBC 鋁青銅
7.	Seat 座封	NBR / EPDM / VITON 合成橡膠
8.	Vent Cap 排氣口蓋	DUCTILE CAST IRON 球墨鑄鐵 / SCS 鑄不銹鋼 / ALBC 鋁青銅

FEATURES 設計特點

- Quick air valve is designed to rapidly release air within the pipeline; therefore, it is suitable to install at the pump outlet.
常裝設於泵浦出水口及需要快速排除管內空氣之管線上。
- It's internal body design allows the float ball to perform up-and-down motions quickly in response to the valve's on-off function.
其閥內之特殊結構設計，使浮球能快速下降並迅速開啟閥門。
- During the fluid transporting in a fully contained pipeline, it can release accumulated air through the plug to prevent accruing air pockets from affecting the water flow performance.
滿管送水時，能透過塞頭之小孔排出管中累積之微小空氣，避免管線形成氣囊，影響輸水效率。

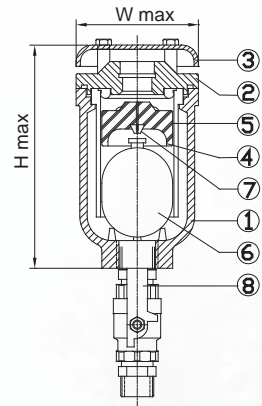

DN20-50

DIMENSION 尺寸表

DIM. SIZE	W	H
	max	max
20	120	250
25	120	250
50	215	390



功能曲線圖 CHARACTERISTIC CURVE

NOTE: SHADED AREAS INDICATE NON STANDARD OPTIONS
註:標示口徑的曲線為參考值。

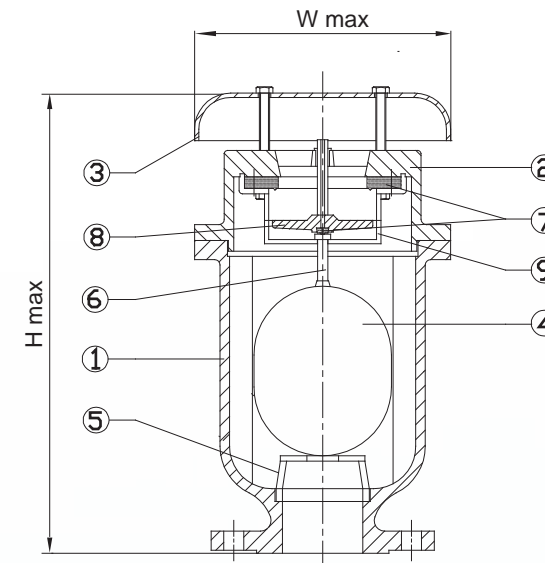
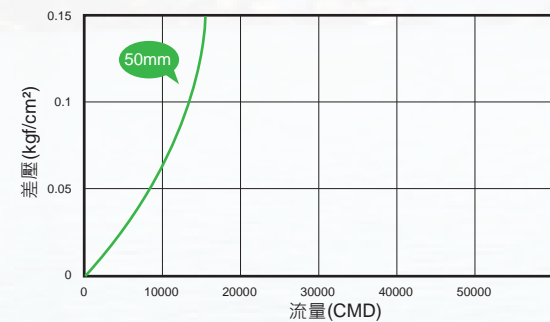
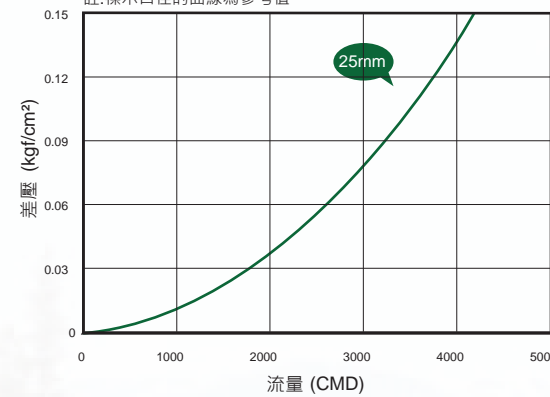

DN50-200
DIMENSION 尺寸表

DIM. SIZE	W	H
	max	max
50	215	390
75	270	480
100	315	610
150	550	580
200	600	650



功能曲線圖 CHARACTERISTIC CURVE

NOTE: SHADED AREAS INDICATE NON STANDARD OPTIONS
註:標示口徑的曲線為參考值。

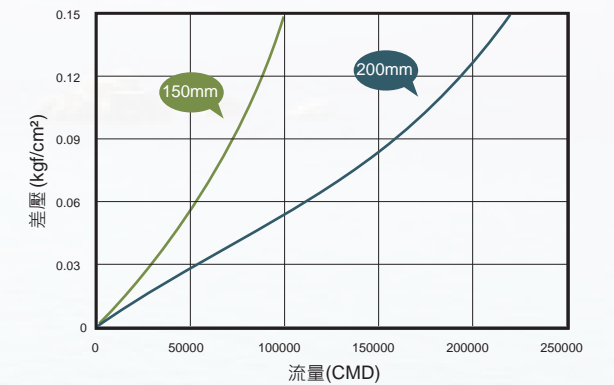
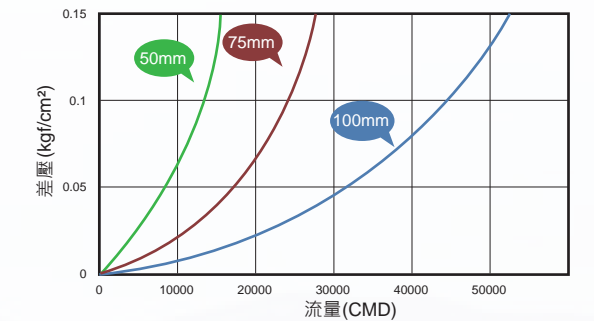

PARTS & MATERIAL 零件材質表

NO.	PARTS 零件	MATERIAL 材質
1.	Body 閥體	DUCTILE CAST IRON 球墨鑄鐵
2.	Cover 上閥蓋	DUCTILE CAST IRON 球墨鑄鐵
3.	Vent Cap 排氣口蓋	DUCTILE CAST IRON 球墨鑄鐵
4.	Plug 塞頭	INDLISTRY PLASTIC 工程塑膠
5.	Plug Holder 塞頭承座	INDLISTRY PLASTIC 工程塑膠
6.	Float Ball 浮球	STAINLESS STEEL 不銹鋼
7.	Seat 座封	NBR / EPDM / VITON 合成橡膠
8.	Cock 考克	STAINLESS STEEL 不銹鋼 / BRONZE 青銅

PARTS & MATERIAL 零件材質表

NO.	PARTS 零件	MATERIAL 材質
1.	Body 閥體	DUCTILE CAST IRON 球墨鑄鐵
2.	Cover 上閥蓋	DUCTILE CAST IRON 球墨鑄鐵
3.	Vent Cap 排氣口蓋	DUCTILE CAST IRON 球墨鑄鐵
4.	Float Ball 浮球	STAINLESS STEEL 不銹鋼
5.	Float Base 浮球座	STAINLESS STEEL 不銹鋼 / ALBC 鋁青銅
6.	Axis 浮桿	STAINLESS STEEL 不銹鋼
7.	Seat 座封	NBR / EPDM / VITON 合成橡膠
8.	Plug 塞頭	STAINLESS STEEL 不銹鋼 / BRONZE 青銅
9.	Plug Holder 塞頭承座	STAINLESS STEEL 不銹鋼 / ALBC 鋁青銅

FEATURES 設計特點

- Applicable in sewage treatment plants' pipelines.
常裝設於污水處理廠管線上。
- Sewage air valves' float and lever design makes the float ball stay at the bottom part of the valve.
閥內部連桿機構經特殊設計，使浮球處於閥內底層。
- This design can minimize the chance of letting the long-term stems clog the vent and further affect the plug's sealing.
結構設計能使污物不易阻塞排氣口以及纏繞至閥內上部進而影響密封性能。

FEATURES 設計特點

- SURGE VALVE is designed to install in the air valve's outlet. When the pump starts (or the pipeline is filled close to fully contained), it can prevent the slam induced by the sudden increase in flow rate and damage the air valve's components.
裝設於排氣閥入口端，防止泵浦啟動瞬間或管線幾近滿管時流速突然加快衝擊排氣閥內部機件，導致零件損壞或排氣閥不足。
- As the pipeline is filled, liquid can rush into the air valve and cause the water to spill rapidly; this problem can be avoided as the connected surge valve closes its plug to limit the flow so the air valve can close smoothly.
滿管時，大量的水湧入排氣閥歧管，突波緩衝塞閥先行關閉塞頭減少進水，使排氣閥緩慢關閉，避免管水瞬間溢流。

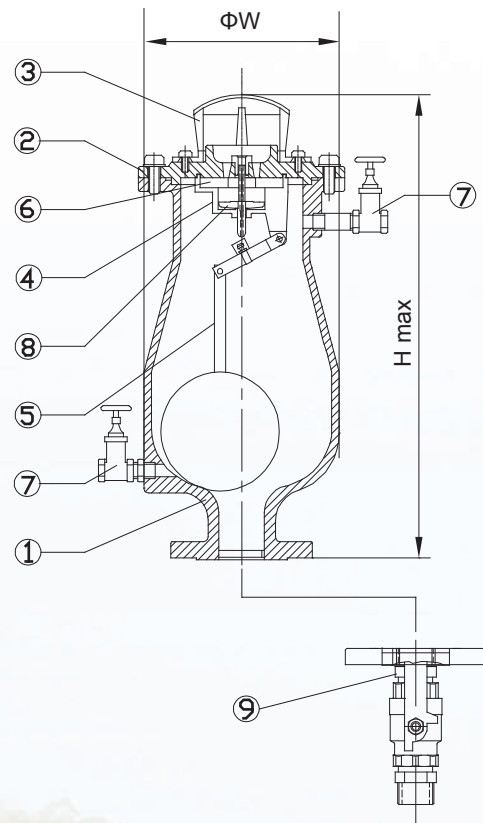

**DN25-200
DIMENSION 尺寸表**

DIM. SIZE	Φ W	H
		max
20	220	510
25	220	510
50	220	510
75	270	710
100	270	710
150	320	750
200	350	1000

PARTS & MATERIAL 零件材質表

NO.	PARTS 零件	MATERIAL 材質
1.	Body 閥體	DUCTILE CAST IRON 球墨鑄鐵 / SCS 鑄不銹鋼 / ALBC 鋁青銅
2.	Cover 上閥蓋	DUCTILE CAST IRON 球墨鑄鐵 / SCS 鑄不銹鋼 / ALBC 鋁青銅
3.	Vent Cap 排氣口蓋	DUCTILE CAST IRON 球墨鑄鐵 / SCS 鑄不銹鋼 / ALBC 鋁青銅
4.	Lever Frame 槓桿架	SCS 鑄不銹鋼 / ALBC 鋁青銅
5.	Float & Lever 浮球及槓桿	STAINLESS STEEL 不銹鋼
6.	Seat 座封	NBR / EPDM / VITON 合成橡膠
7.	Sluice 清洗柱	STAINLESS STEEL 不銹鋼 / BRONZE 青銅
8.	Plug 塞頭	STAINLESS STEEL 不銹鋼 / BRONZE 青銅
9.	Cock 考克	STAINLESS STEEL 不銹鋼 / BRONZE 青銅

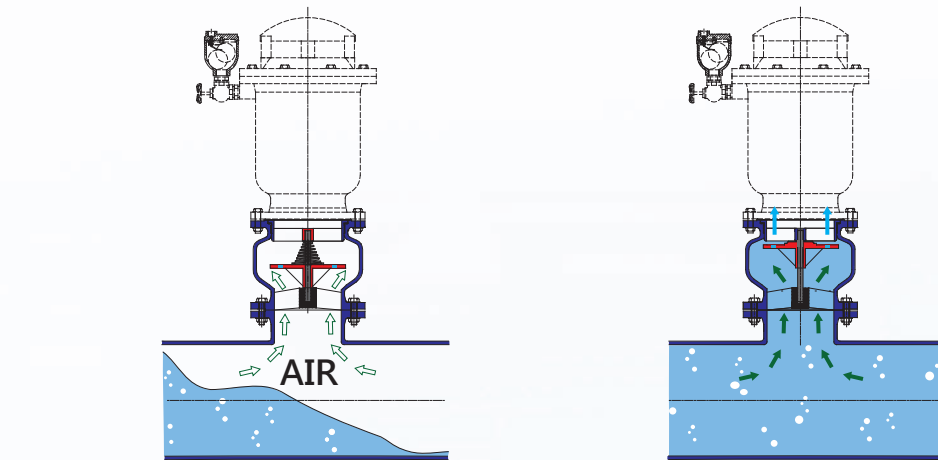

**DN75-400
DIMENSION 尺寸表**

DIM. SIZE	H	ØW
	max	max
75	130	231
100	150	258
150	230	310
200	260	362
250	310	430
300	330	484
400	470	602

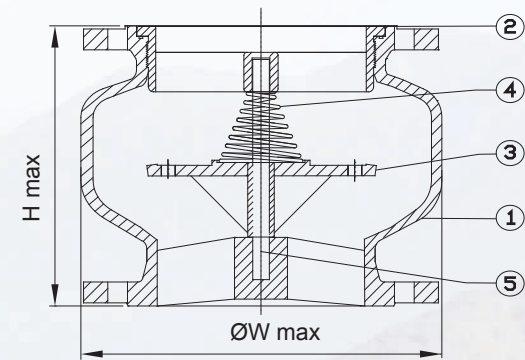

PARTS & MATERIAL 零件材質表

NO.	PARTS 零件	MATERIAL 材質
1.	Body 閥體	DUCTILE CAST IRON 球墨鑄鐵 / SCS 鑄不銹鋼 / ALBC 鋁青銅
2.	Fixing Ring 固定環	DUCTILE CAST IRON 球墨鑄鐵 / SCS 鑄不銹鋼 / ALBC 鋁青銅
3.	Plug 塞頭	STAINLESS STEEL 不銹鋼
4.	Spring 彈簧	STAINLESS STEEL 不銹鋼
5.	Axis 固定軸	STAINLESS STEEL 不銹鋼

HOW DO DECIDE THE SIZE OF AIR VALVES FOR PIPELINES

如何選擇管線中的排氣閥口徑

General Expansion Of Criteria Used 一般情況使用準則

1. Calculate the required amount and size of air valves based on each pipeline's highest point.
依據每一個管線高點計算需要的排氣閥。
2. Examine the slopes of the uphill and downhill on both sides of each noticeable high point along the pipeline.
瞭解管線中每一個明顯高點兩邊的上坡及下坡斜率。
3. Determine the maximum flow rate for filling/ draining of the line, and ensure this maximum flow rate can cover the highest flow rate induced by gravity/ pump under critical conditions.
計算填充/排水時之最大流速; 確保此流速保泵浦供水或重力送水之最大可能流速。

FLOW RATE CALCULATION 流量計算

If line is being filled by pump

泵浦供水

$$\text{Rate of flow C.F.S} = \frac{\text{CMD of pump}}{449}$$

$$\text{流量CMD} = \text{泵出水量CMS} \times 86,400$$

If line is being drained by gravity

重力送水

$$\text{Rate of flow in C.F.S} = 0.08666 (SD^5)^{\frac{1}{2}}$$

$$\text{流量CMD} = 0.06785 (SD^5)^{\frac{1}{2}}$$

Where S = Slope(in feet per foot of length)

S = 水力坡度(高差/長度)

D = Diameter of pipe (inches)

D = 管線直徑(mm)

4. The air valve installed at high point must be able to exhaust/ inject the amount of air (CMD) that is equivalent to the highest possible flow rate (CMD) to its adjacent line.
安裝於高處之排氣閥必須能排出/吸入足以等同於附近管線之最大液體流速的空氣量。
5. Using the selected air valve type's characteristic curves to make an economical choice for the valve's size that can sustain the maximum allowance pressure difference.
運用選擇之排氣閥種類之功能區線圖及管線最大容許壓差和需要之排氣量決定最符合經濟效益的排氣閥口徑。
6. Air valves should be located at high points, and every air valve installed should pair with a shut-off valve at its bottom.
排氣閥必須安裝在每個管線高點處，並在排氣閥下方處裝設關段閥。

7. The maximum pressure difference must consider the risk of pipe collapse due to vacuum, especially to a pipeline larger than 600DN, where it is more likely to occur.
決定最大容許差壓必須估算管線因真空塌陷的風險，這個情況通常發生在DN600 以上的薄管管線中。

TO CALCULATE COLLAPSING PRESSURE FOR THIN-WALLED-CYLINDRICAL PIPE:

計算薄管壁容許坍塌壓力:

$$P=12,500,000 (T/b)^3$$

Collapsing pressure (PSI)

T=Thickness of pipe (inches)

D=Diameter of pipe (inches)

This includes a safety factor of 4

$$P=879,000 (T/b)^3$$

容許坍塌壓力 (kgf/cm²)

管身厚度 (mm)

管身外徑 (mm)

已包含安全係數4

8. Consider the case of draining and air intake, use the calculated maximum pressure differential if it is lower than 0.35 kgf/cm², else use 0.35 kgf/cm². Select the valve's size using this pressure difference and the draining flow rate on the valves' characteristic curve, which can ensure the selected valve can protect the line from pipe collapse or water column separation due to vacuum.
當考慮排水時，選擇計算之最大差壓若小於0.35 kgf/cm²則用此差壓為計算參數; 反之若大於0.35kgf/cm²則用0.35 kgf/cm² 來計算。運用選擇之排氣閥種類之功能區線圖及管線最大容許壓差和需要之排氣量決定排氣閥口徑，以避免管線因水柱分離或真空造成塌陷。
9. Consider the case of filling and air release, use the maximum filling flow rate and pressure difference of 0.14 kgf/cm² to select the appropriate sizing for the valve. This step ensures the selected air valve can release sufficient air before valve closure and keep the line at maximum flowing performance.
當考慮進水時，則用0.14 kgf/cm²為管線最大容許壓差並配合管線最高流速決定排氣閥口徑，以確保管線的最大輸水效益。
10. Comparing steps 8 and 9, use the largest size for this particular line.
對比前兩步之排氣閥口徑，選擇其中最大的口徑。
11. Suppose the line lacks clearly defined high points or the points are separated by a long stretched uniform gradient. In that case, following the above procedures to select a proper size of the air valve and install them at regular intervals of 500m to 1000m is recommended.
若管線無明顯高點或這些不明顯高點分布在一個斜坡上，建議依述原則來選擇排氣閥數量及口徑並考慮在每500~1000米安裝同型排氣閥。
12. When a line is in operation, Air Pockets collect both at the high point and for a distance downstream from the high point. To release the Air, install the Combination/ Quick Air Release Valve at high point and a second Automatic Air Valve a short distance downstream.
當管線正常輸水時，氣囊通常集中於高點及離高點下游一段的位置; 為了排除這些氣囊建議在高點設置複合式/ 急速式排氣閥並在離高點下游一段的位置設置自動釋氣閥。