

DEVICE TYPE 安裝型式

Extension-Operated Driver 提升操作蝶閥



Pneumatic Actuator 氣動蝶閥



Motor Actuator 電動蝶閥



Since 1966



SK VALVES

BUTTERFLY VALVES

蝶型閥

ISO 9001 APPRPVED

- FLANGE TYPE / 法蘭型 (8"~104")
- LUG TYPE / 多耳型 (2"~28")
- WAFER TYPE / 夾持型 (2"~28")



Hydraulic Actuator
油壓控制蝶閥

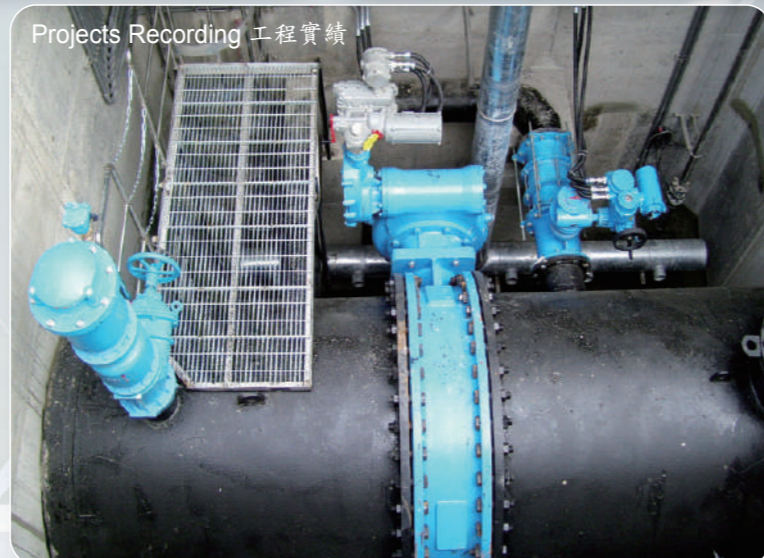

Projects Recording 工程實績



叶光閥業股份有限公司 SHYE KUANG VALVES MFG CO.,LTD.
恩盈企業股份有限公司 EN IN ENTERPRISE CO.,LTD.

■ 總公司 Headquarter

923屏東縣萬巒鄉佳興路83號 No. 83, Chia-Hsing Rd., Wan-Luan, Pingtung 923, Taiwan R.O.C.
TEL : +886-8-783-3834 FAX : +886-8-783-3734 Skype: skvalve.andrew
E-mail: international@skvalves.com.tw

■ 北區辦公室 North Taiwan Office

241新北市三重區環河北路三段270號1樓
No. 270, Sec. 3, Huanhe N. Rd., Sanchong Dist., New Taipei City 241076, Taiwan R.O.C.
TEL : +886-2-2988-4657 FAX : +886-2-2988-4657



www.skvalves.com.tw

■ 本公司對型錄所列之材質與尺寸保留認為必要時作修改之權利，或依客戶需求設計，實際尺寸及材質仍以客戶訂購時所提供之圖說為準。

SK Valves reserves the right to modify the materials or/and dimensions of the products as provided hereunder from time to time if necessary, or in accordance with the request of clients. The actual dimensions or/and material used are subject to the customer's request after placing the order.

Our butterfly valve's shaft and seat design provides on-center, single, double, and tri-eccentric options, which differ in the number of offsets relating to the shaft and the disc.

蝶型閥依閥座與閥軸中心或閥體中心的相對位置可分為中軸型蝶閥、單偏心蝶閥、雙偏心蝶閥、三偏心閥

Centric Shaft 中軸型設計

Centric-type butterfly valves have no offset, which makes This type of butterfly valve has a fully rubber-lined body, protecting the body against corrosion buildup; since the entire valve's inlet is lined with rubber, the shaft has no contact with liquid.

中軸型蝶閥通常為全內襯橡膠設計，且閥瓣具有雙面持壓特性，閥體內襯之軸部橡膠可以完全隔絕閥軸與流體接觸，是構造簡單便宜的高C/P值蝶閥。

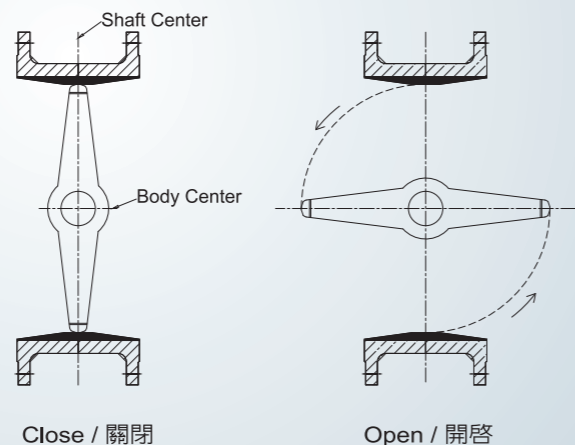

Single Eccentric 單偏心設計

Single eccentric design offsets the shaft from the body center of the discs, reducing the compression and wearing between the discs and the seat during open/close operation.

當閥瓣開啓時，閥座封會與閥座逐漸分離，當全開時唯有靠近閥軸兩側部分的座封會與閥座接觸但趨近於分離狀態，此設計型式比中軸型設計更為優良，能減少蝶閥在操作行程中座封與閥座之間所產生的擠壓和磨損。

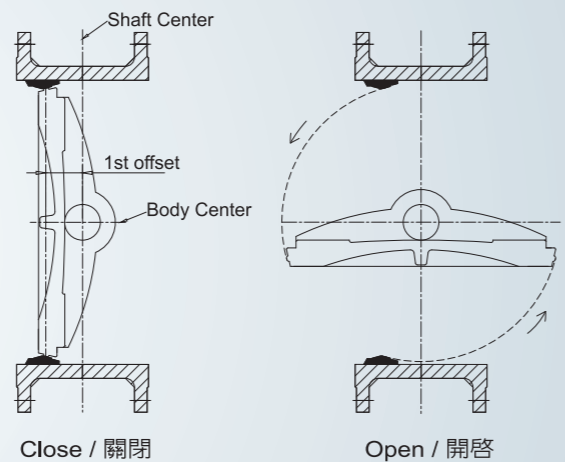

Dual Eccentric 雙偏心設計

Double eccentric construction has a better sealing function on the designed fluid-flowing side. The advantages of 2nd offset on the disc include reducing friction and torque required during the operation of open/close, so as a longer service time.

The double eccentric dramatically decrease the wearing and compression between the disc and the seat while the disc is opening/closing. The disc is entirely separate from the seat when it is fully open.

雙偏心的閥座設計，使閥瓣位於全關位置時，擁有更理想的密封耐壓性能，並且能有效降低操作扭矩以及增加座封的使用壽命。

當閥瓣開啓時，閥座封與閥座能更快的分離，且當全開時座封與閥座能徹底分離，能避免靠近閥軸兩側部分的座封產生永久性變形，影響閥的密封性能。

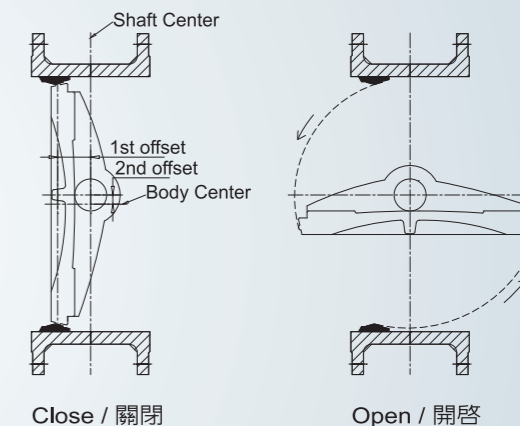

Tri-Eccentric 三偏心設計

Tri-Eccentric construction further enhances the sealing function and reduces the operating torque; therefore, the valve's service time can be extended further.

When the disc opens, the entire disc will leave the seat immediately; throughout the stroke, the disc will not touch the seat. For a tri-eccentric design, the seat and disc are metal to metal. It is suitable to work under high-pressure and high-temperature working environments.

三偏心的閥座設計，使閥瓣位於全關位置時，擁有完美的密封耐壓性能，並且能大大降低操作扭矩以及大大增加座封的使用壽命。

當閥瓣開啓時，座封與閥座能立刻的分離，操作過程中幾乎無任何的摩擦行程，能徹底消除座封與閥座間所產生的機械磨損和擦傷，因此通常應用於金屬-金屬的閥座設計，適用於高溫、高壓的流體環境。

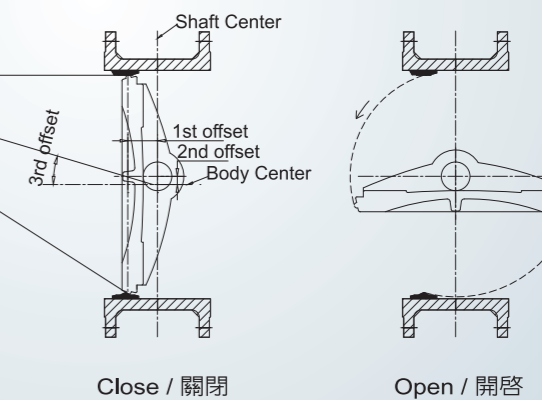

PRODUCT DESCRIPTION 產品概說

The joint configuration (flange-type, lug-type, and wafer-type joint) and requested international standards can be changed upon customer order.

本公司生產之蝶型閥依管線系統接頭的配置型式可分為法蘭型、多耳型、及夾持型，且可符合API609、AWWA C504、AWWA C516、ISO5752、BS 5155、JIS B2032、JWWA B138等國際規範。

Flange type butterfly valve

- The valve body has long-type and short-type, which differ in end-to-end distance between two flanges.
- Based on the shaft orientation, the butterfly valve can break into two categories: vertical-type and horizontal-type.
- In flange-type butterfly valves, we provide the option of centric、single, double, and tri-eccentric designs.
- Driving mode: manual gear, pneumatic actuator, and motor actuator
- Application: water pipeline, sewage, chemical fluid, gas
- For seawater usage, a rubber-lined body can serve to prevent corrosion.

Size range: 2"~104" (50mm~2600mm)
Pressure class: 125LB/150LB/250LB/300LB
PN10/PN16
7.5K/10K/16K

法蘭型蝶閥

- 依法蘭端距可為長體型或短體型。
- 依閥軸方向可分為立式或臥式。
- 結構設計可為中軸型、單偏心、雙偏心、三偏心。
- 驅動方式: 手動型、氣動型、電動操作型。
- 應用範圍: 自來水、污水、海水、化學流體、氣體...等。
- 為了配合不同系統之需求，閥體、閥瓣、閥軸、閥座...等零件材質可依客戶要求生產。
- 用於海水管線之閥體或閥瓣可採內襯橡膠設計以防止腐蝕

尺寸範圍: 2"~104" (50mm~2600mm)
壓力等級: 125LB/150LB/250LB/300LB
PN10/PN16
7.5K/10K/16K



Lug type butterfly valve

- The compact design allows this type of butterfly valve to install in a tight space.
- Can be used on dead-end service with a downstream flange attached
- In lug-type butterfly valves, we provide the option of centric double and tri-eccentric designs.
- Driving mode: manual gear, pneumatic actuator, and motor actuator
- Application: water pipeline, sewage, chemical fluid, gas
- Material of the parts can be changed upon customer request

Size range: 2"~48" (50mm~1200mm)
Pressure class: 125LB/150LB/250LB/300LB
PN10/PN16
10K/16K

多耳型蝶閥

- 有極短之端距優勢，安裝空間小。
- 可與法蘭接頭作配合，亦適合作為管末端用閥。
- 結構設計可為中軸型、雙偏心、三偏心。
- 驅動方式: 手動型、氣動型、電動操作型
- 應用範圍: 自來水、污水、海水、化學流體、氣體...等
- 為了配合不同系統之需求，閥體、閥瓣、閥軸、閥座...等零件材質可依客戶要求生產

尺寸範圍: 2"~48" (50mm~1200mm)
壓力等級: 125LB/150LB/250LB/300LB
PN10/PN16
10K/16K



Wafer type butterfly valve

- Wafer joint configuration allows users to install the valve in tight space and without additional screws
- The valve's seat structure is designed to be removable, which can be easily removed for maintenance/ replacement.
- In wafer-type butterfly valves, we provide the option of centric double and tri-eccentric designs.
- Driving mode: manual gear, pneumatic actuator, and motor actuator
- Application: water pipeline, sewage, chemical fluid, gas
- Material of the parts can be changed upon customer request

Size range: 2"~48"(50mm~1200mm)
 Pressure class: 125LB/150LB/250LB/300LB
 PN10/PN16
 10K/16K

夾持型蝶閥

- 薄式夾持型設計，安裝空間小。
- 閥座採可拆卸式構造利於方便維修與更換。
- 結構設計可為中軸式、雙偏心、三偏心。
- 驅動方式: 手動型、氣動型、電動操作型。
- 應用範圍: 自來水、污水、海水、化學流體、氣體...等。
- 為了配合不同系統之需求，閥體、閥瓣、閥軸、閥座..等零件材質可依客戶要求生產。

尺寸範圍: 2"~48"(50mm~1200mm)
 壓力等級: 125LB/150LB/250LB/300LB
 PN10/PN16
 10K/16K

TYPE OF THE BUTTERFLY VALVE 蝶閥型式

JOINT TYPE 接頭型式	WAFER 夾持型	LUG 多耳型	FLANGE 法蘭型
DESIGN MODLE 設計型式			
CENTRIC 中軸式			
SINGLE ECCENTRIC 單偏心			
DUAL ECCENTRIC 雙偏心			
TRI-ECCENTRIC 三偏心			

Annotations: COST BIAS 成本趨勢 (blue arrow pointing right), PERFORMANCE BIAS 性能趨勢 (blue arrow pointing down), PRICE BIAS 價格趨勢 (red arrow pointing down-right).

STROKE & Cv CURVE 閥行程與流量係數曲線圖

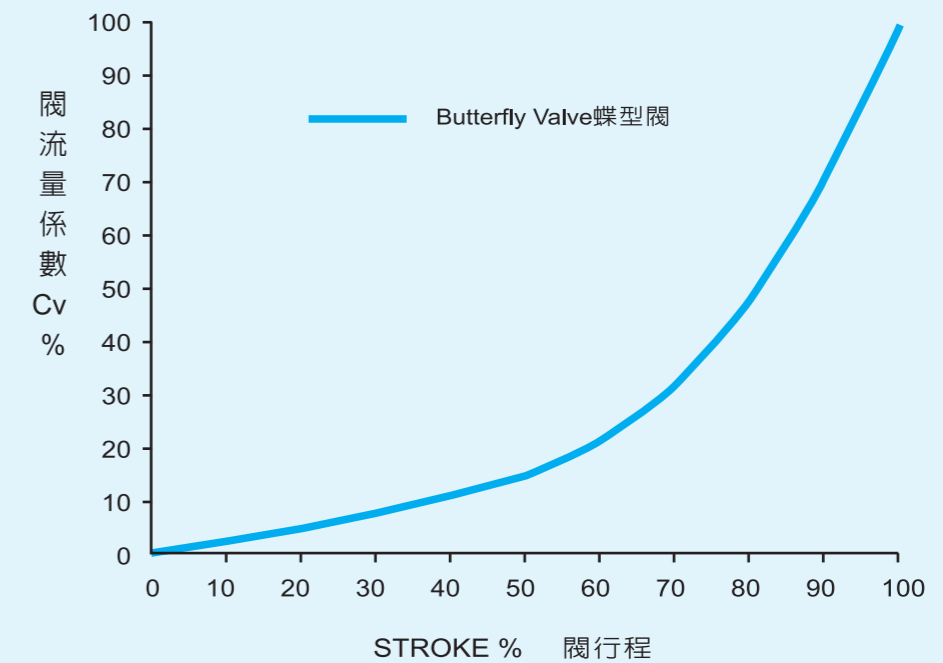



Eccentric flange type butterfly valve
偏心式法蘭型蝶閥

DN 200~900

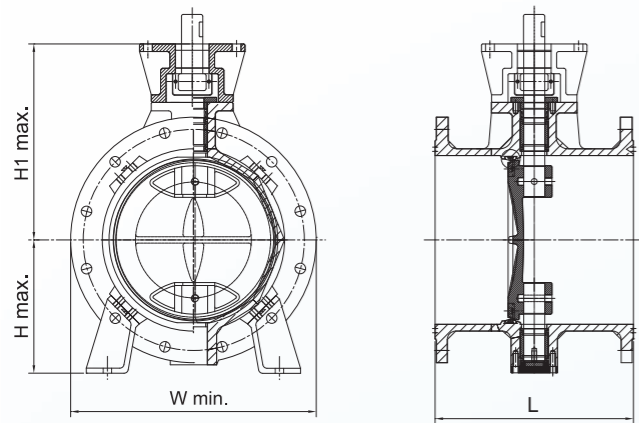

DN 1000~2600

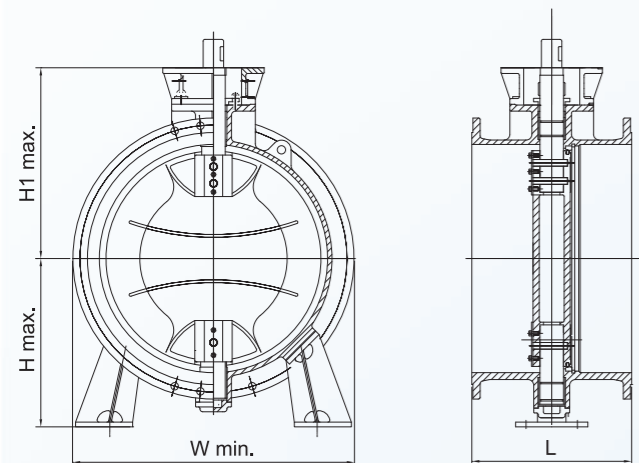

ECCESTRIC MAX. OPERATING TORQUE
偏心式最大操作扭力參考值

Ref.	Kgf-m	
CLASS SIZE	PN 6	PN 10
200	15.4	21.4
250	26.5	38.3
300	43.4	61.9
250	64	90.9
400	90	137
450	122	186
500	175	247
600	272	403
700	420	613
800	614	887
900	860	1230
1000	1170	1660
1100	1540	2240
1200	1990	2870
1350	2730	4010
1500	3740	5430
1650	5120	7390
1800	7060	10300
2000	9745	13295
2200	12505	18350
2400	16360	24120
2600	20250	29120

DIMENSIONS 尺寸表 mm

DIM. SIZE	L		W	H1	H
	long	short	min.	max.	max.
200	300	152	300	450	350
250	380	203	400	600	350
300	400	203	450	650	400
250	430	203	500	650	450
400	470	203	550	650	450
450	500	203	650	750	500
500	530	203	700	750	500
600	560	203	800	800	600
700	610	305	900	900	650
800	690	305	1000	900	700
900	740	305	1150	1050	750
1000	770	305	1250	1450	800
1100	800	305	1350	1450	900
1200	820	381	1450	1550	950
1350	850	381	1600	1600	1050
1500	900	381	1800	1650	1200
1650	1000	457	1900	1650	1350
1800	1250	457	2100	1700	1500
2000	1250	490	2300	1700	1600
2200	1350	530	2400	1800	1700
2400	1500	580	3100	1900	1800
2600	1505	660	3400	2000	1900

ECCESTRIC PARTS & MATERIAL / 偏心式零件材質

1. Body 閥體: Ductile Cast Iron 球墨鑄鐵
Stainless Steel 不鏽鋼
2. Seat seal 座圈: Stainless Steel 不鏽鋼
3. Disc 閥盤: Ductile Cast Iron 球墨鑄鐵
Stainless Steel 不鏽鋼
4. Seat 閥座: Rubber/ EPDM / Neoprene 合成橡膠
5. Shaft 閥軸: Stainless Steel 不鏽鋼
6. Pin 固定銷: Stainless Steel 不鏽鋼
7. Bush 軸套: Teflon 鐵弗龍 / Bronze 銅合金
8. Packing 填料: Reinforced Nylon / Teflon Fiber 纖維填料



Eccentric wafer type butterfly valve
偏心夾持型 / 偏心多耳型蝶閥

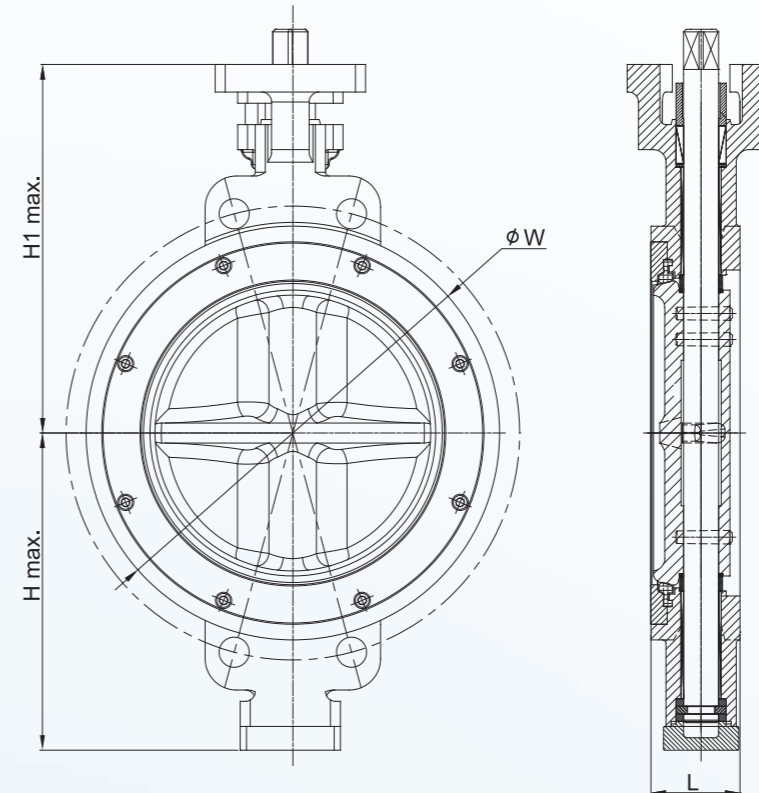

ECCESTRIC MAX. OPERATING TORQUE
偏心式最大操作扭力參考值

Ref.	Kgf-m			
CLASS SIZE	PN 6	PN 10	PN 16	PN 25
65	2.8	3.3	3.8	5.4
80	3.2	3.9	4.4	6.7
100	4.6	5	5.7	8.1
125	6.5	7.8	9.2	13.2
150	8.6	11	12.5	18.6
200	11	17	22	30
250	21	26	31	47
300	30	38	53	84
350	52	76	97	130
400	64	96	113	145
450	93	121	143	188
500	148	178	211	293
600	178	239	285	358

DIMENSIONS 尺寸表 mm

DIM. SIZE	L	phi W	H max.	H1 max.
	65	46	121	101
80	48	132	135	139
100	53	156	140	166
125	57	187	154	180
150	57	216	163	192
200	64	267	198	253
250	71	330	253	294
300	78	375	265	321
350	92	423	305	435
400	102	480	338	480
450	114	534	356	498
500	127	584	385	535
600	154	692	452	610

ECCESTRIC PARTS & MATERIAL / 偏心式零件材質

1. Body 閥體: Cast Steel 鑄鋼 / Stainless Steel 不鏽鋼
2. Seat Seal 座圈: Stainless Steel 不鏽鋼
3. Disc 閥盤: Ductile Cast Iron 球墨鑄鐵
Stainless Steel 不鏽鋼
4. Seat 閥座: Teflon 鐵弗龍
5. Shaft 閥軸: Stainless Steel 不鏽鋼
6. Pin 固定銷: Stainless Steel 不鏽鋼
7. Packing 填料: Teflon 鐵弗龍

Centric flange type butterfly valves
中軸法蘭型蝶閥

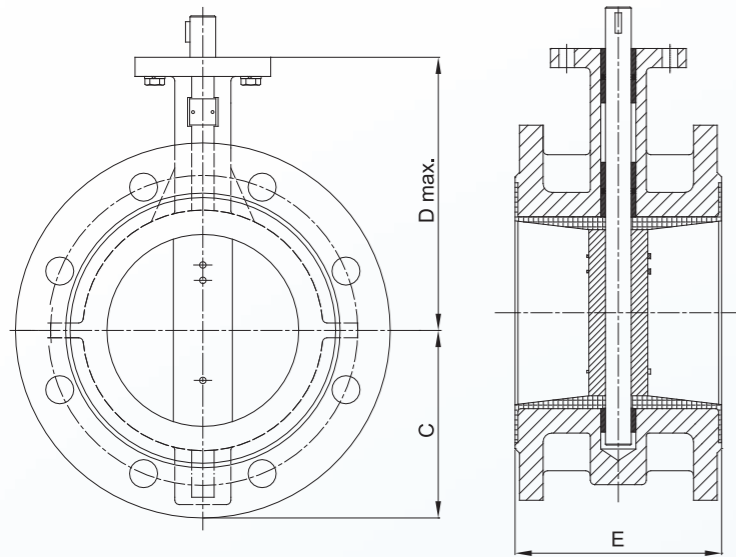

DIMENSIONS 尺寸表 mm

DIM SIZE	C	E	D max.
50	66	43	168
65	79	46	178
80	91	46	186
100	110	52	203
125	124	56	216
150	140	56	237
200	176	60	289
250	210	68	321
300	240	78	373
350	274	78	390
400	315	102	400
450	345	114	430
500	390	127	498
600	465	154	575
700	520	165	614

Centric wafer type butterfly valve
中軸對夾持型蝶閥

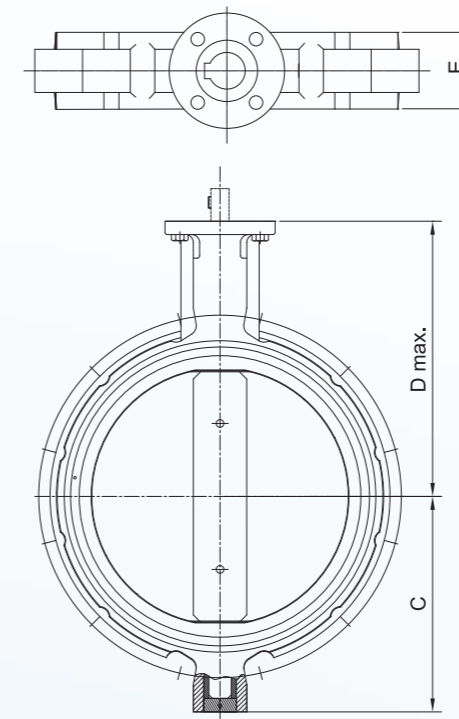

DIMENSIONS 尺寸表 mm

DIM SIZE	C	E	D max.
50	66	43	168
65	79	46	178
80	91	46	186
100	110	52	203
125	124	56	216
150	140	56	237
200	176	60	289
250	210	68	321
300	240	78	373
350	274	78	390
400	315	102	400
450	345	114	430
500	390	127	498
600	465	154	575
700	520	165	614

Centric lug type butterfly valve
中軸多耳型蝶閥

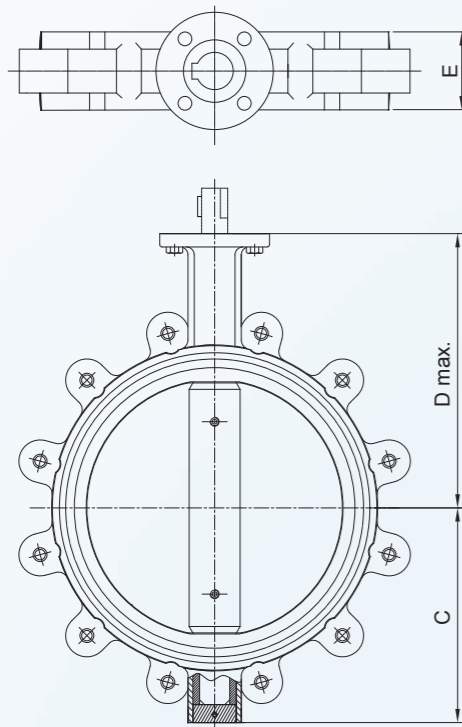

DIMENSIONS 尺寸表 mm

DIM SIZE	C	E	D max.
50	66	43	168
65	79	46	178
80	91	46	186
100	110	52	203
125	124	56	216
150	140	56	237
200	176	60	289
250	210	68	321
300	240	78	373
350	274	78	390
400	315	102	400
450	345	114	430
500	390	127	498
600	465	154	575
700	520	165	614

CENTRIC PARTS & MATERIAL / 中軸式零件材質

1. Body 閥體: Ductile Cast Iron 球墨鑄鐵
Stainless Steel 不鏽鋼
Carbon Steel 碳鋼
2. Seat 閥座: Rubber/ EPDM
Neoprene 合成橡膠
Teflon 鐵弗龍
3. Disc 閥盤: Ductile Cast Iron 球墨鑄鐵
Stainless Steel 不鏽鋼
Carbon Steel 碳鋼
4. Shaft 閥軸: Stainless Steel 不鏽鋼
5. Pin 固定銷: Stainless Steel 不鏽鋼
6. Bush 軸套: Teflon 鐵弗龍
Bronze 銅合金

CENTRIC MAX. OPERATING TORQUE
中軸式最大操作扭力參考值

Ref. Kgf-m

CLASS SIZE	PN 6	PN 10
50	2.3	2.5
65	3.1	3.4
80	4.1	4.5
100	6.8	7.5
150	16.1	17.8
200	28.7	33.7
250	47.6	56
300	69.4	81.6
350	84.1	98.9
400	113.4	133.4
450	146	182.4
500	186.8	233.5
600	303	378.7
700	521	651
800	686	857.2