



Since 1966

SK VALVES

HYDRAULIC CONTROL VALVES 水力控制閥



TUBELESS TYPE / 無配管型

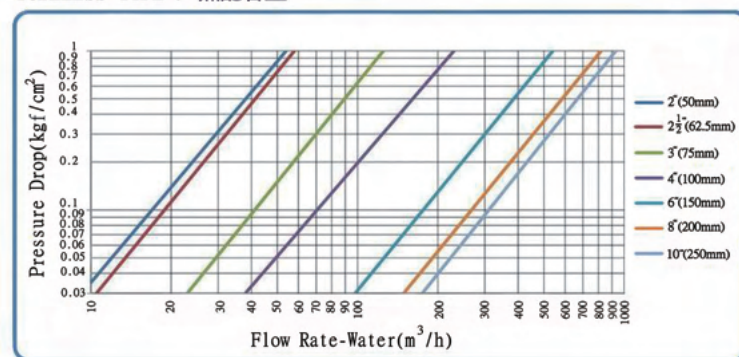

DIAPHRAGM TYPE / 隔膜型

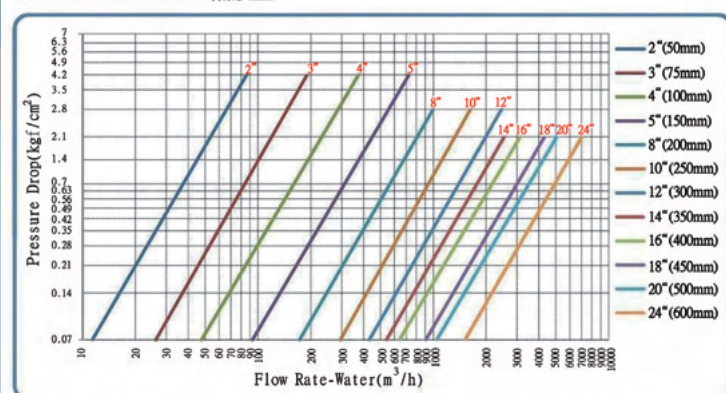

PISTON TYPE / 汽缸型

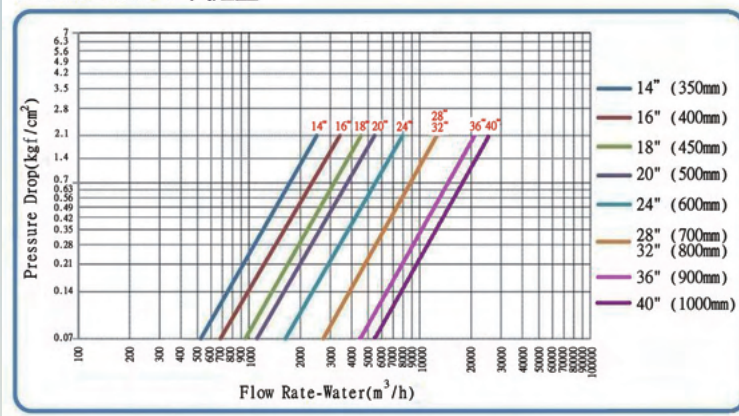

- DIAPHRAGM TYPE / 隔膜型 (2"~32")
- PISTON TYPE / 汽缸型 (14"~54")
- TUBELESS TYPE / 無配管型 (2"~10")
- PRESSURE TYPE / 水壓管理型 (2"~32")



叶光閥業股份有限公司 SHYE KUANG VALVES MFG CO.,LTD.
恩盈企業股份有限公司 EN IN ENTERPRISE CO.,LTD.

■ 總公司 Headquarter

923屏東縣萬巒鄉佳興路83號 No. 83, Chia-Hsing Rd., Wan-Luan, Pingtung 923, Taiwan R.O.C.
TEL : +886-8-783-3834 FAX : +886-8-783-3734 Skype: skvalve.andrew
E-mail:international@skvalves.com.tw

■ 北區辦公室 North Taiwan Office

241新北市三重區環河北路三段270號
1F., No. 270, Sec. 3, Huanhe N. Rd., Sanchong Dist., New Taipei City 241076, Taiwan R.O.C.
TEL : +886-2-2988-4657 FAX : +886-2-2988-4657



www.skvalves.com.tw

Hydraulic Control Valve is operated hydraulically, designed to move by driving pressure difference between upside chamber and downside chamber which are caused by diaphragm or piston in valve. The diaphragm or piston divides the actuator into two distinct pressure chambers, and the control system list are also including disc, cock, tube, spring, needle valve and pilot valve.

Whenever the upside diaphragm chamber exceeds to the downside chamber in force (caused by pipeline pressure), the disc is enforced to close. Otherwise the disc is opened by pressure of downside chamber, pipeline system maintainers are able to operate the valve by driving the pilot valve and setting pressure balance of both pressure chambers, which could make the valve to be used in a wide range of applications.

水力型控制閥主要是藉由隔膜或活塞所形成的壓力室、閥盤、控制管路、針閥、響導閥所建構成的水力動態平衡系統，以達到設計之控制目的。

當壓力室所形成之推力大於管線動水對閥盤的推力則閥盤關閉；當壓力室所形成之推力小於管線動水對閥盤的推力則閥盤開啓；當壓力室所形成之推力等於管線動水對閥盤的推力則閥盤處於平衡的浮動調節狀態，而此平衡位置操作人員可藉由響導閥設定。

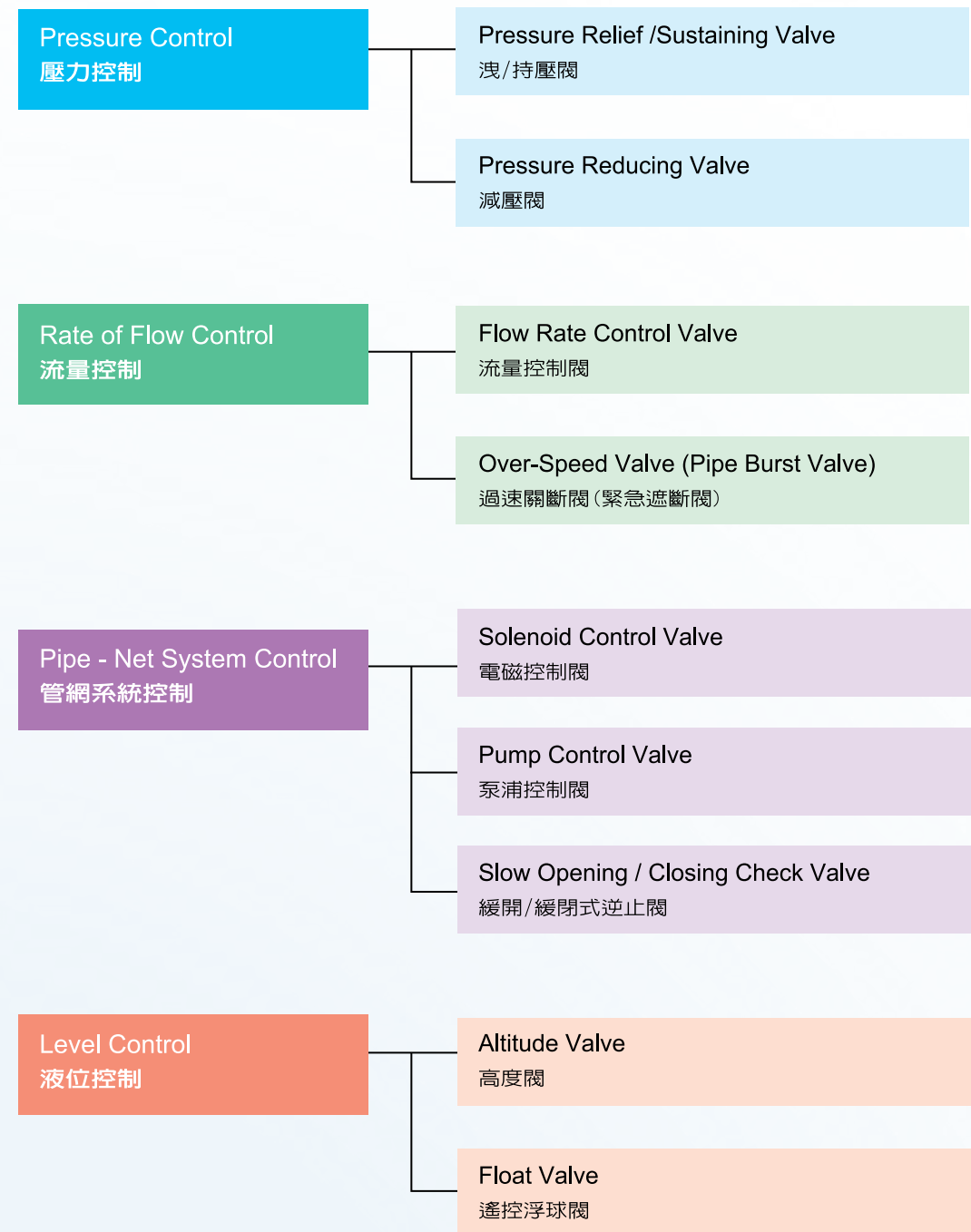
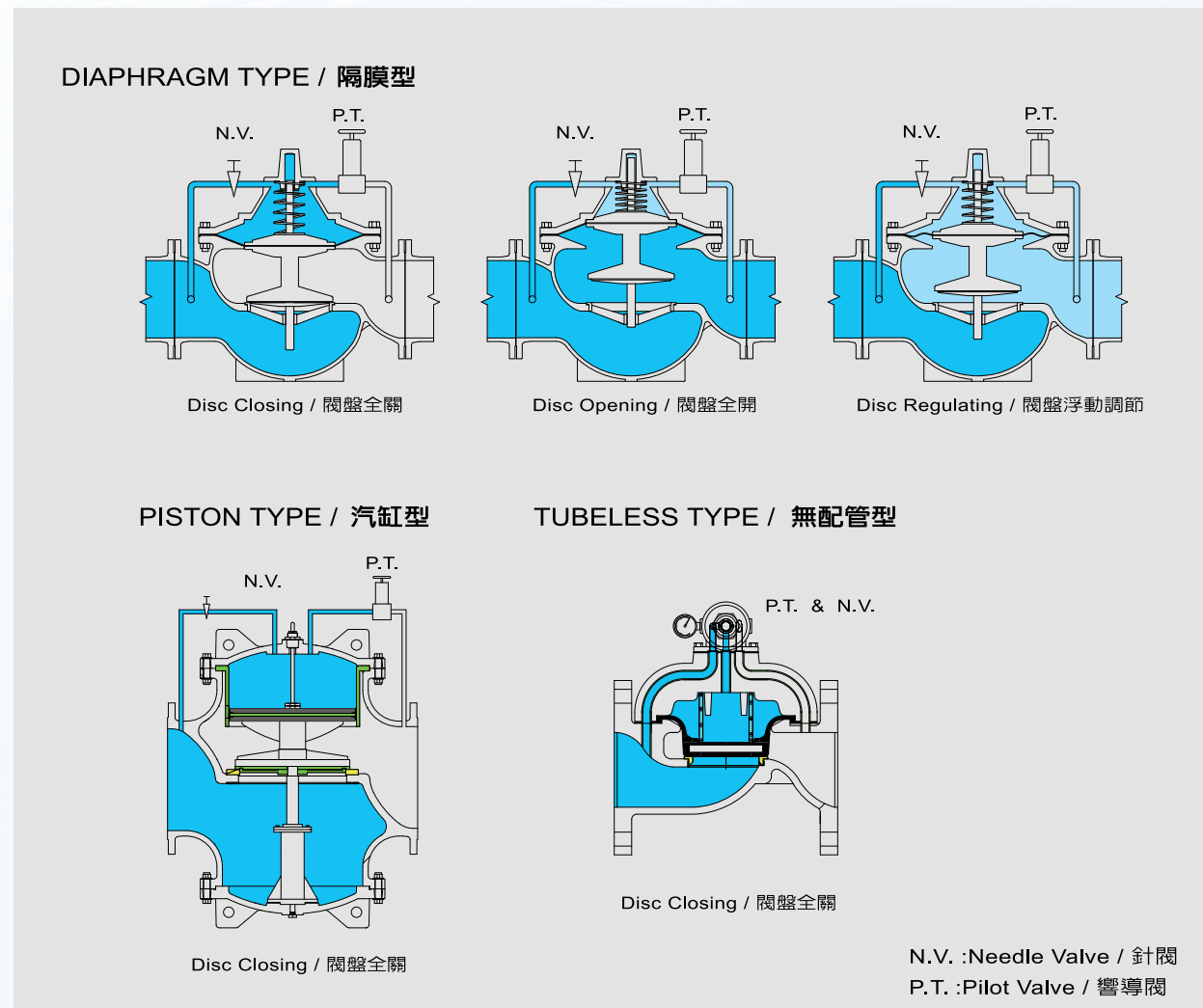

The combination designs of several functions are available. For instance pressure sustaining & reducing valve, pump control & pressure sustaining valve, level control & electrical remote....etc. If you need any special function, please contact us.

我們能提供兼具數個功能的設計，例如持壓兼減壓閥、泵浦控制閥兼持壓功能、液位控制閥兼遠端控制功能..等，如果您需要其它特殊的供能設計，請聯絡我們。

PRESSURE CONTROL SERIES

壓力控制閥系列



GBD-RL SERIES

PRESSURE RELIEF/SUSTAINING VALVE 洩/持壓閥

The valve works for controlling pressure of upstream of pipeline. Preventing inlet pressure of valve higher than user's preset value. Whenever inlet pressure of valve exceeds user's preset pressure, valve will be opened fast to prevent inlet pressure over allowable pressure. Oppositely, valve will be closed slowly when inlet pressure of valve is lower than preset pressure. (Relief function) In the other way, it could prevent upstream main transmission pipeline still supply downstream minor pipeline when the pressure of main transmission pipeline is lower than the lowest delivery pressure. (Sustaining function)

此型閥主要控制閥前端管線壓力，防止閥入口端壓力高於使用者的設定壓力。當閥入口端壓力高於設定壓力時，主閥快速開啓並維持調節狀態；當閥入口端壓力低於設定壓力時，主閥自動關閉，因此可確保閥入口端壓力於容許壓力範圍之內(洩壓功能)。除此之外，亦可用於防止上游主要輸水管線在低於基本送水壓力時，仍供給下游次要配水管線(持壓功能)。



GBD-RD SERIES

PRESSURE REDUCING VALVE 減壓閥

The valve works for controlling pressure of downstream of pipeline. Maintaining a constant outlet pressure of valve at user's preset value. Regardless of inlet pressure of valve or rate of flow of pipeline changing, the valve will be modulated to maintain a constant outlet pressure of valve at user's preset pressure automatically to prevent outlet pressure over allowable pressure.

此型閥主要控制閥後端管線壓力，維持穩定的閥出口端壓力於使用者設定壓力之內。無論閥入口端壓力變化或閥出口端管線用水量多寡，主閥自動增加或減少開度並維持調節狀態，以維持閥出口端供水壓力穩定，並防止閥出口端供水壓力超過容許範圍。

LIQUID LEVEL CONTROL SERIES

液位控制閥系列



GBD-FL SERIES

FLOAT VALVES 遙控浮球閥

The valve be installed at inlet of a water tank. Adjusting water level in predetermined rang to prevent the water overflow from reservoir or tank. Whenever water level lower than the shut-off location of float, valve will be opened for refilling reservoir or tank, and valve will be closed when water level reach to the shut-off location of float to prevent overflow.

此型閥主要配置於蓄水池上方或下方之進水管上，控制蓄水池水位於浮球設定的範圍之內以防止蓄水池溢流。當水池水位低於浮球裝設水位時主閥開啓補充水量；當水位達到浮球裝設水位時，主閥關閉停止進水，因此可防止蓄水池的水溢流。

GBD-AL SERIES

ALTITUDE VALVES 高度閥

The valve be installed at inlet of a water tank. Adjusting water level in predetermined rang to prevent the water overflow from reservoir or tank. Whenever water level lower than user predetermined level, valve will be opened for refilling reservoir or tank, and valve will be closed when water level reach to user predetermined level to prevent overflow. If two-way function is required, valve could be opened to return water from reservoir or tank when inlet pressure of valve is lower than level head.

此型閥主要配置於蓄水池下方進水管上，控制蓄水池水位於設定的範圍之內以防止蓄水池溢流。當水池水位低於設定水位時主閥開啓補充水量；當水位達到設定之高水位時主閥關閉停止進水，因此可防止蓄水池的水溢流。如果雙向流功能被指定時，當閥進口端水壓低於蓄水位水頭時，水能從蓄水池流回配水管中。

PIPE - NET SYSTEM CONTROL SERIES 管網系統控制閥系列



GBD-SP SERIES

PUMP CONTROL VALVES 泵浦控制閥

The valve is installed on the discharge side of pump to prevent starting and stopping surges. The valve will be opened gradually when pump start up, and the valve will be closed slowly before pump shutdown, and the speed of opening and closing of valve are adjustable. When power failure occurred, the valve can immediately close to prevent return flow to damage pump. Therefore the valve could minimize surge, slam, and water hammer of pipeline to protect pump better than any check valves.

裝設於泵浦出口端以配合泵浦作動。當泵浦起動時主閥閥盤依設定自動緩慢開啓，當泵浦欲停機時主閥閥盤可先行緩速關閉，再停止泵浦運轉，且各行程速度可依需要調整，此外當遇電力中斷時能自動迅速關閉防止管線中的水逆流，因此可減少管線的突壓、水擊及水錘現象，增加泵浦的使用壽命。



GBD-SD(GBD-SC) SERIES

ELECTRICAL REMOTE VALVES 電磁控制閥

The valve can be controlled by electrical signal. Both normally open (N.O.) type and normally close (N.C.) type are available, and the speed of opening and closing of valve are adjustable. Therefore users can control the process in accordance with electrical signal such as various pressure or flow rate.

以電子訊號來控制主閥的啓閉，有常開型及常閉型二種型式，且啓閉速度可依需要調整，因此可配合各種壓力或流量訊號作程序控制。

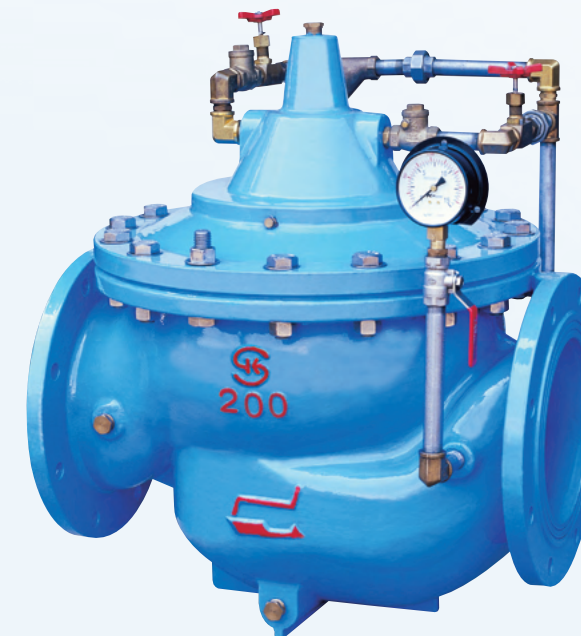

GBD-CV SERIES

SLOW OPENING/CLOSING CHECK VALVES 緩開/緩閉式逆止閥

The valve is installed on the discharge side of pump or separate pipeline to prevent return flow. The speed of opening and closing of valve are adjustable. Therefore the valve could be applied widely in prevent return flow better than any check valves.

裝設於泵浦出口端或配水管線中，當作一緩閉之逆止閥，且啓閉速度可依需要調整，因此可減少管線的水擊及水錘現象。



PRESSURE MANAGEMENT SERIES

水壓管理閥系列



Pressure-Scheduled Type
水壓管理閥 (時間控制型)

Pressure-Scheduled Type can switch two sets of pressure in six different time zones in one day. The schedule can be set with a paired Bluetooth controller unit. Moreover, a 4G Wireless Datalogger can be applied to monitor its performance For Practical management purposes. (Control and signal transmission processes do not depend on the utility power.)
此閥功能可依高低壓二組響導閥所設定之壓力在設定時間內進行切換控制，利用藍牙控制器可預先設定每日某個時段的壓力切換排程 (每日最多可設定六個時段)，並搭載4G無線傳輸記錄器能隨時監測及記錄壓力變化以有效管理管網水壓且控制及訊號傳輸不需要市電。

4G Communication Mode
4G 無線傳輸記錄器

Pressure Management series offers 4G Communication Mode. This mode will store data logs (pressure, flow rate, water quality, etc.) based on the set time or period (1 to 1440 minutes); simultaneously, it allows users to automatically receive data logs and alarm signals in network pockets and text messages. In addition, the 4G Wireless Datalogger will enable users to connect all meters (pressure meter, flow meter, water quality monitor, etc.).
4G通訊模式 (網路封包及簡訊) 定時間/定距離 (1至1440分鐘) 自動回傳資料依時段設定流量與壓力警報區間輸入訊號多元，可連接各式設備 (如水壓、流量及水質監測計)。



(4G無線傳輸記錄器)

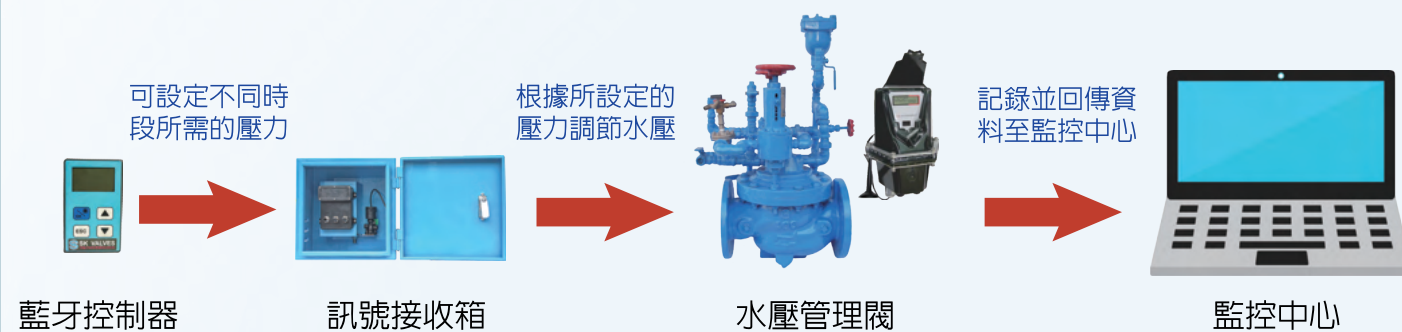

Pressure Management Smart Type
水壓管理閥 (智慧管理型)

Pressure Management Smart Type possesses the ability that Pressure-Scheduled Type can do, for instance, monitor, record data logs, and alarm. Furthermore, it offers users to monitor and adjust the pressure through the network or close-range Bluetooth pairing. This function enables users to react to an urgent situation immediately. (Control and signal transmission processes do not depend on the utility power.)
此閥功能可經由網路定時回傳壓力訊號至監控中心並透過監控中心或手機APP隨時監測壓力狀況，並依現場狀況可由監控中心進行遠端壓力設定值調整，也可利用手機藍牙連線現場進行壓力設定值調整，此模組也可於偵測到壓力異常時及時發送示警至監控中心或手機，讓相關人員能夠立即處理排除狀況以達到完整管理之目的且控制及訊號傳輸不需要市電。

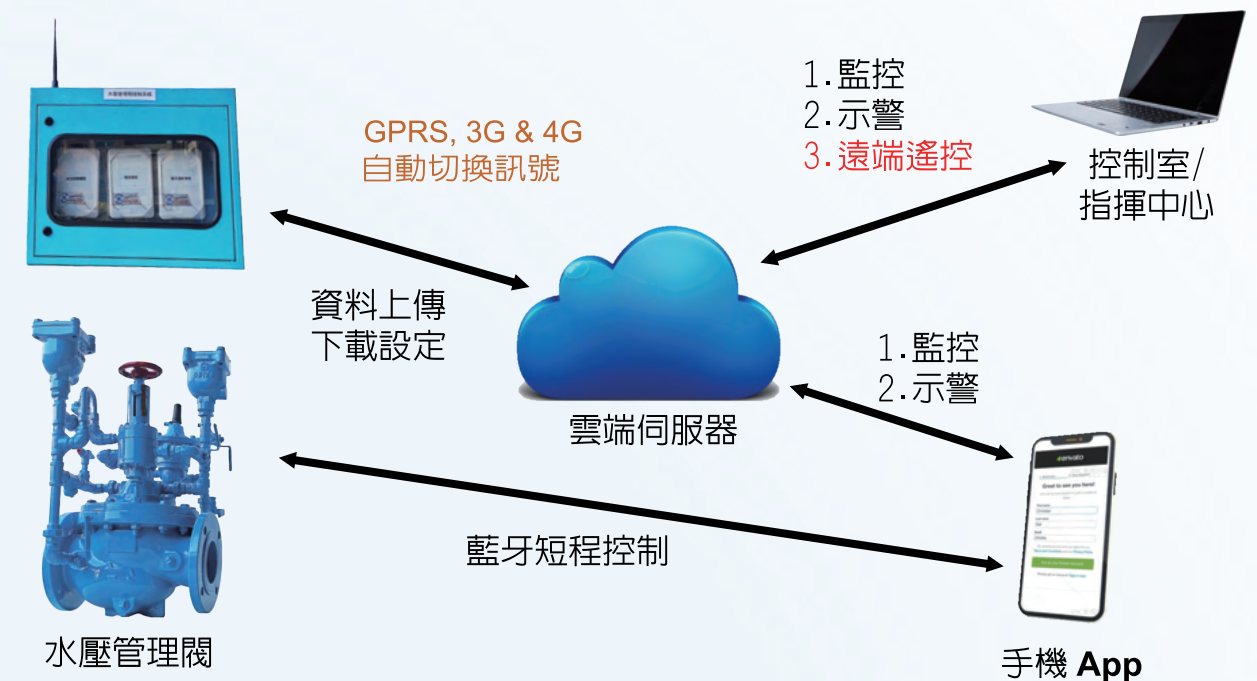

RATE OF FLOW CONTROL SERIES
流量控制閥系列



GBD-FW SERIES

FLOW RATE CONTROL VALVES 流量控制閥

Maintains a constant rate of flow of pipeline at user's preset value. Regardless of inlet/outlet pressure of valve changing, the valve will be modulated to maintain a constant rate of flow at user's preset range automatically to prevent supply to over allowable rate of flow.

維持管線的流量於使用者設定的範圍之內。無論管線壓力如何變化，主閥閥盤自動增加或減少開度並維持調節狀態，以維持管線供水量穩定，並防止下游供水量超過容許範圍。

BBF-EE(ME) SERIES

PIPE BURST CONTROL VALVES 緊急遮斷閥

The valve will be shut off automatically when rate of flow of pipeline exceed user's preset value. Whenever the valve will be closed fast to reduce waste when rate of flow of pipeline is over user's preset value suddenly on downstream pipeline burst. And user can reset valve when pipeline will supply again.

當管線的流量高於使用者的設定流量時強制關閥。當管線流量因破管高於設定流量時，主閥能快速關閉以減少漏水浪費。當欲恢復通水時，只要重新設定即可。

GDB-X DIAPHRAGM TYPE
隔膜型

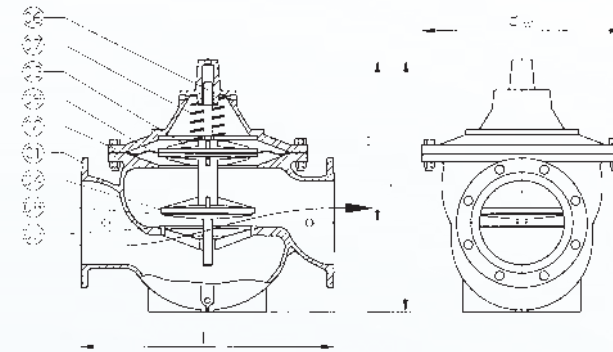

NO	PARTS 零件	MATERIAL 材質
01	Body 閥體	Ductile Cast Iron 球墨鑄鐵
02	Cover 閥蓋	Ductile Cast Iron 球墨鑄鐵
03	Diaphragm Plate 隔膜壓盤	Ductile Cast Iron 球墨鑄鐵 Bronze 青銅 Stainless steel 不銹鋼
04	Disc 閥盤	Ductile Cast Iron 球墨鑄鐵 Bronze 青銅 Stainless steel 不銹鋼
05	Seat 閥座	Bronze 青銅 Stainless steel 不銹鋼
06	Shaft 閥軸	Stainless steel 不銹鋼
07	Spring 彈簧	Stainless steel 不銹鋼
08	Seal 座封	NBR / EPDM / VITON 各式高級橡膠
09	Diaphragm 隔膜	Nylon Reinforced Neoprene 尼龍強化橡膠

DIMENSIONS / 主閥尺寸

unit : mm

SIZE	2"	3"	4"	6"	8"	10"	12"	14"	16"	18"	20"	24"	32"
DIM.	DN50	DN80	DN100	DN150	DN200	DN250	DN300	DN350	DN400	DN450	DN500	DN600	DN800
L	203	285	360	455	585	790	900	962	962	1076	1076	1232	1750
W	162	204	280	378	500	610	710	835	835	1035	1035	1232	1473
T	230	280	360	500	645	765	910	1035	1035	1300	1300	1560	1823
H	150	170	235	330	420	495	590	685	685	880	880	1050	1235

GBP-X PISTON TYPE
汽缸型

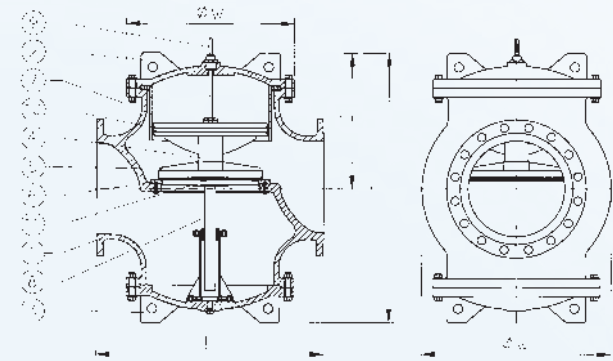

NO	PARTS 零件	MATERIAL 材質
01	Body 閥體	Ductile Cast Iron 球墨鑄鐵
02	Cover 閥蓋	Ductile Cast Iron 球墨鑄鐵
03	Bottom 底座	Ductile Cast Iron 球墨鑄鐵
04	Piston 活塞	Ductile Cast Iron 球墨鑄鐵 Bronze 青銅 Stainless steel 不銹鋼
05	Disc 閥盤	Ductile Cast Iron 球墨鑄鐵 Bronze 青銅 Stainless steel 不銹鋼
06	Seat 閥座	Bronze 青銅 Stainless steel 不銹鋼
07	Cylinder 汽缸	Stainless steel 不銹鋼
08	Shaft 閥軸	Stainless steel 不銹鋼
09	Indicator 開度指示桿	Stainless steel 不銹鋼
10	Piston Seal 汽缸封環	NBR / EPDM / VITON 各式高級橡膠
11	Seal 座封	NBR / EPDM / VITON 各式高級橡膠

DIMENSIONS / 主閥尺寸

unit : mm

SIZE	14"	16"	18"	20"	24"	28"	30"	32"	36"	40"	Up from 54"
DIM.	DN350	DN400	DN450	DN500	DN600	DN700	DN750	DN800	DN900	DN1000	Up from DN1350
L	864	962	1076	1076	1232	1750	1750	1750	2250	2250	Design for custom require available
W	820	820	950	950	1100	1350	1350	1350	1592	1592	
T	1150	1150	1320	1320	1450	1860	1860	1860	1735	1735	
H	575	575	660	660	725	930	930	930	1180	1180	

MATERIAL & DIMENSION 材質與尺寸

TUBELESS SERIES 無配管型控制閥系列

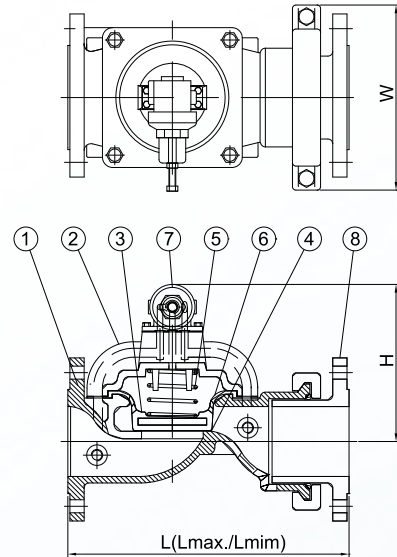
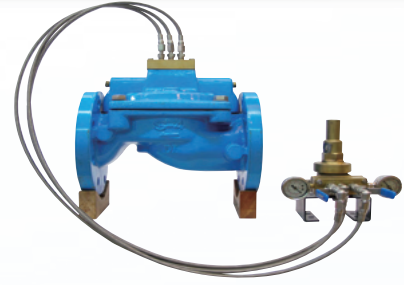

零件材質表

NO	PARTS 零件	MATERIAL 材質
1	Body 閥體	Casting Stainless Steel 鑄不銹鋼
2	Cover 閥蓋	Casting Stainless Steel 鑄不銹鋼
3	Flapper 閥瓣包膠	NBR / EPDM / VITON 合成橡膠
4	Seat 閥座	Bronze 青銅
5	Spring 彈簧	Stainless steel 不銹鋼
6	Diaphragm 隔膜	Nylon Reinforced Neoprene 尼龍強化橡膠
7	Pilot valve 嚮導閥	Bronze 青銅 Stainless steel 不銹鋼彈簧
8	Flexible joint 伸縮管	Ductile Cast Iron 球墨鑄鐵

DIMENSIONS / 主閥尺寸

SIZE	2"	3"	4"	6"	8"	10"
DIM.	DN50	DN75	DN100	DN150	DN200	DN250
Lmin	265	340	390	435	605	800
L	275	350	400	450	620	820
Lmax	285	360	410	465	635	840
(Lmax-Lmin)	20	20	20	30	30	40
W (max.)	210	260	310	385	460	540
H (max.)	210	240	270	320	370	430

unit : mm

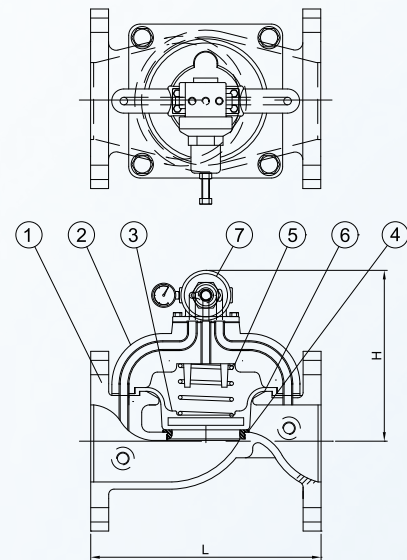

零件材質表

NO	PARTS 零件	MATERIAL 材質
1	Body 閥體	Casting Stainless Steel 鑄不銹鋼
2	Cover 閥蓋	Casting Stainless Steel 鑄不銹鋼
3	Flapper 閥瓣包膠	NBR / EPDM / VITON 合成橡膠
4	Seat 閥座	Bronze 青銅
5	Spring 彈簧	Stainless steel 不銹鋼
6	Diaphragm 隔膜	Nylon Reinforced Neoprene 尼龍強化橡膠
7	Pilot valve 嚮導閥	Bronze 青銅 Stainless steel 不銹鋼彈簧

DIMENSIONS / 主閥尺寸

SIZE	2"	3"	4"	6"	8"	10"
DIM.	DN50	DN75	DN100	DN150	DN200	DN250
L	203	285	360	455	585	790
H (max.)	210	240	270	320	370	430

unit : mm

SPECIFICATIONS 規格說明

Pressure Class & Flange / 壓力等級 & 法蘭規格				Fluid / 適用流體
Standard 規格	Class 等級	Operating Pressure 工作壓力	Flow Rate Range 流速範圍	Clean Water 清水
ANSI	125	10 - 175 psi	Normal Service 常態流速 1.5 - 15 ft/sec 0.5 - 5 m/sec	Fluid Temperature Range / 流體溫度
	250	10 - 300 psi		0 - 80 ° C / 32 - 176 ° F (Liquid 液態)
ISO / DIN / BS	PN10	0.7 - 10 kgf/cm ²	Intermittent Service 容許瞬間流速 25 ft/sec 8 m/sec	Testing Pressure / 測試壓力
	PN16	0.7 - 16 kgf/cm ²		According to ISO 5208 (Rate 3) SEAT / 閥座 : 1.1 × Max. Operating Pressure BODY / 閥體 : 1.5 × Max. Operating Pressure
JIS / CNS	7.5 K	0.7 - 7.5 kgf/cm ²		
	10.0 K	0.7 - 10 kgf/cm ²		
	16.0 K	0.7 - 16 kgf/cm ²		

AREA-A 區域A

The cavitation will occur to accelerate wearing.
在此區域氣蝕將可能產生氣蝕現象，加速閥件磨損。

AREA-B 區域B

Normal working rang.
此區域為正常工作範圍。

AREA-C 區域C

Not applicable.
此區域控制閥不適用。

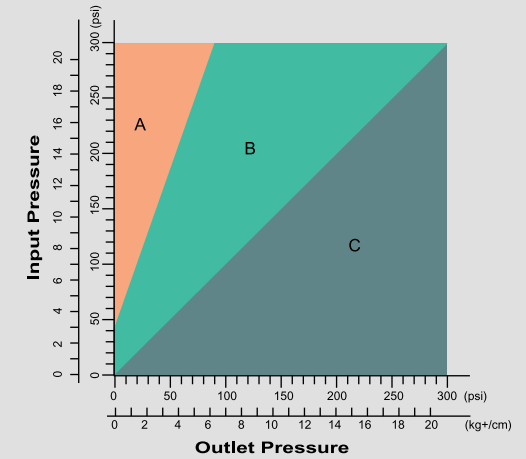

OPTIONAL / 其它選配

Standard Double-Chamber Main Valves 雙密閉壓力室型主閥

The standard Double-Chamber Main Valve provides constant and accurate control.
雙密閉壓力室型主閥可提供較穩定且精準的控制

Angle Pattern Main Valves / 角型主閥

Angle Pattern Main Valve provides different installation selection.

V-Port Plug Module / V-Port 閥塞模組

The V-Port Plug Module can be used for low flow or high differential pressures situation.
V-Port閥塞模組適用於小流量或高壓差的控制場合

Multi-Port Sleeve Module / 多噴孔套筒模組

The Multi-Port Sleeve Module can be used for provides a superior and accurate control, when extreme pressure and flow conditions .
多噴孔套筒模組能提供較優越及精準的控制，尤其在極端的壓力及流量之下。