



Since 1966



# SK VALVES

## DIMENSION

## 閥類尺寸表

The materials and dimension can be improved in certain situation without notice.  
We can also follow customer's design, the actually material and dimension will be provided by workshop drawing when customer placed the purchase order.

本公司對型錄所列之材質與尺寸保留必要時可作修改之權利，  
或依客戶需求設計，實際尺寸及材質仍以客戶訂購時承認圖為準。

叶光閥業股份有限公司 SHYE KUANG VALVES MFG CO.,LTD.  
恩盈企業股份有限公司 EN IN ENTERPRISE CO.,LTD.

■ 總公司 Headquarter

923屏東縣萬樹鄉佳興路83號 No. 83, Chia-Hsing Rd., Wan-Luan, Pingtung 923, Taiwan R.O.C.  
TEL : +886-8-783-3834 FAX : +886-8-783-3734 Skype: skvalve.andrew  
E-mail: international@skvalves.com.tw

■ 北區辦公室 North Taiwan Office

337桃園市大園區致遠一路63號 No. 63, Zhiyuan Rd., Dayuan, Taoyuan 337, Taiwan R.O.C.  
TEL : +886-3-381-7110 FAX : +886-3-381-5308

# BUTTERFLY VALVES 水道用蝶閥

Vertical Type 立式手動蝶閥 DN 200~2600 mm

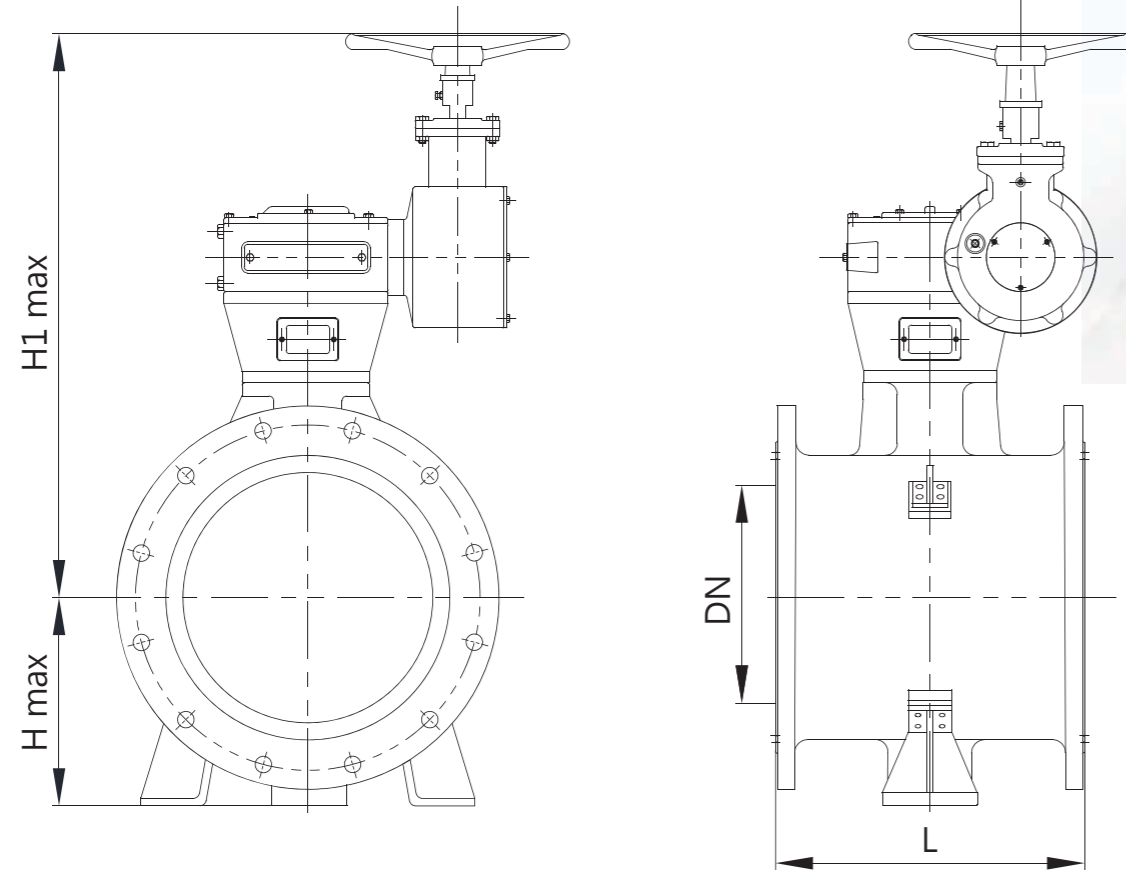

尺寸表/單位 mm

DIM. SIZE	DN	L		H1	H
		Long	Short	max	max
200	200	300	152	950	350
250	250	380	203	1000	350
300	300	400	203	1000	400
350	350	430	203	1050	450
400	400	470	203	1050	450
450	450	500	203	1100	500
500	500	530	203	1100	500
600	600	560	203	1300	600
700	700	610	305	1350	650
800	800	690	305	1500	700
900	900	740	305	1550	750
1000	1000	770	305	1700	800
1100	1100	800	305	1800	900
1200	1200	820	381	1950	950
1350	1350	850	381	2050	1050
1500	1500	900	381	2250	1200
1650	1650	1000	457	2350	1350
1800	1800	1250	457	2500	1500
2000	2000	1250	457	2600	1600
2200	2200	1350	530	2750	1700
2400	2400	1500	580	2900	1800
2600	2600	1500	660	3050	1900



# BUTTERFLY VALVES 水道用蝶閥

Horizontal Type 臥式手動蝶閥 DN 200~2600 mm

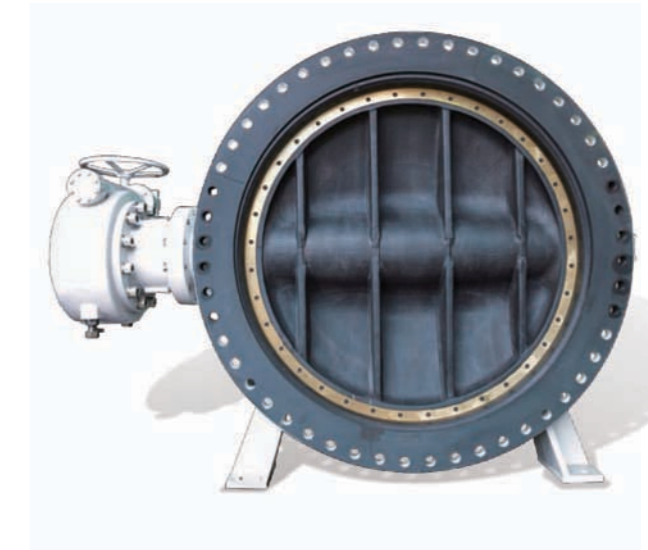
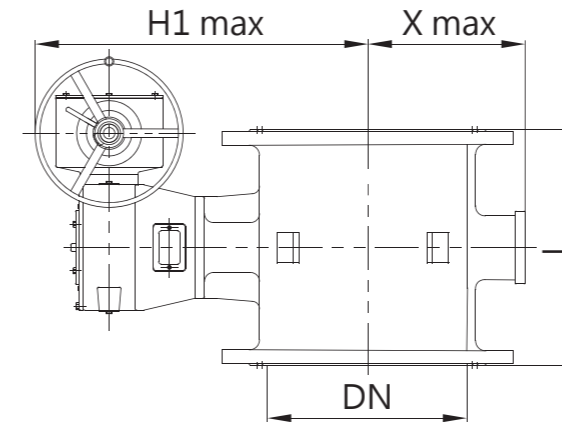

尺寸表/單位 mm

DIM. SIZE	DN	L		H	X	H1	H2
		Long	Short	min	max	max	min
200	200	300	152	200	350	950	400
250	250	380	203	200	350	1000	400
300	300	400	203	200	400	1000	400
350	350	430	203	200	450	1050	400
400	400	470	203	400	450	1050	600
450	450	500	203	400	500	1100	600
500	500	530	203	400	500	1100	600
600	600	560	203	450	600	1300	650
700	700	610	305	500	650	1350	700
800	800	690	305	550	700	1500	750
900	900	740	305	600	750	1550	800
1000	1000	770	305	650	800	1650	850
1100	1100	800	305	700	900	1800	900
1200	1200	820	381	750	950	1950	950
1350	1350	850	381	825	1050	2050	1025
1500	1500	900	381	900	1200	2250	1100
1650	1650	1000	457	1050	1350	2350	1250
1800	1800	1250	457	1150	1500	2500	1350
2000	2000	1250	457	1250	1600	2600	1450
2200	2200	1350	530	1400	1700	2750	1600
2400	2400	1500	580	1550	1800	2900	1750
2600	2600	1500	660	1700	1900	3050	1900

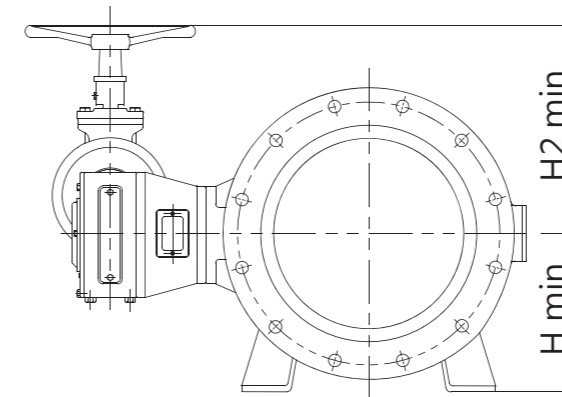

**RESILIENT SEATED GATE VALVES 水道用彈性座封**

Handwheel 手輪型 DN 50~350 mm

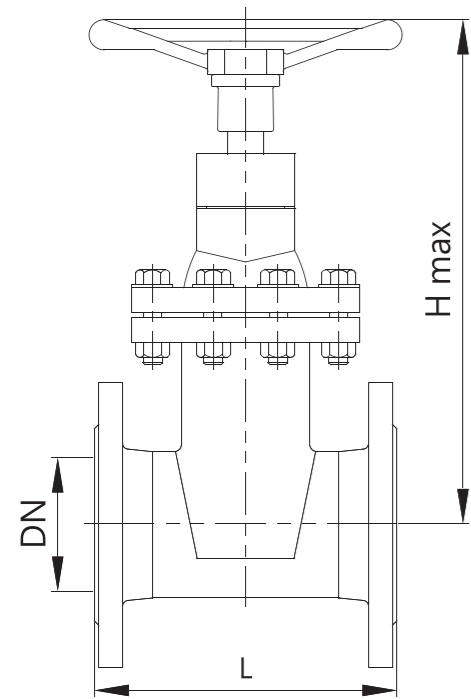

尺寸表/單位 mm

DIM. SIZE	DN	L	H
			max
50	50	180	400
75	75	240	500
100	100	250	550
150	150	280	700
200	200	300	800
250	250	380	900
300	300	400	1000
350	350	430	1100

**ECCENTRIC PLUG VALVES 偏心式栓塞閥**

Lever 把手型 DN 50~200 mm

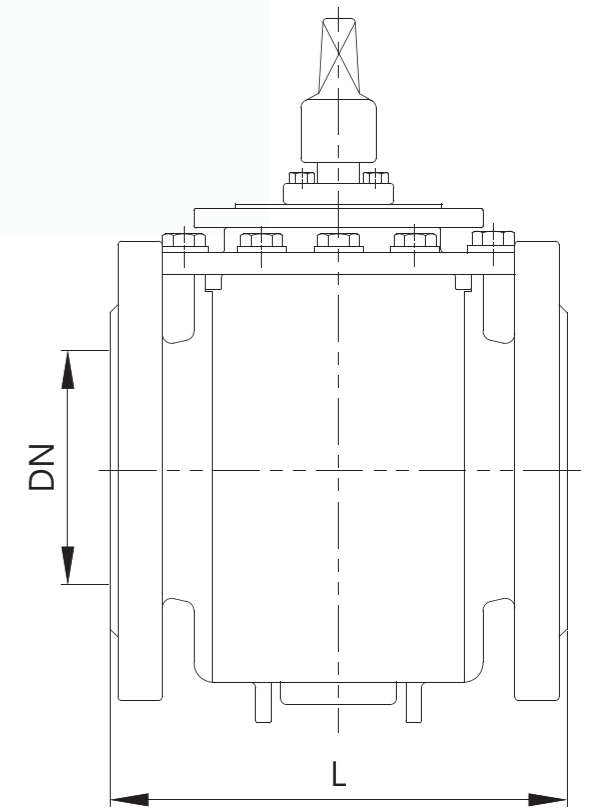
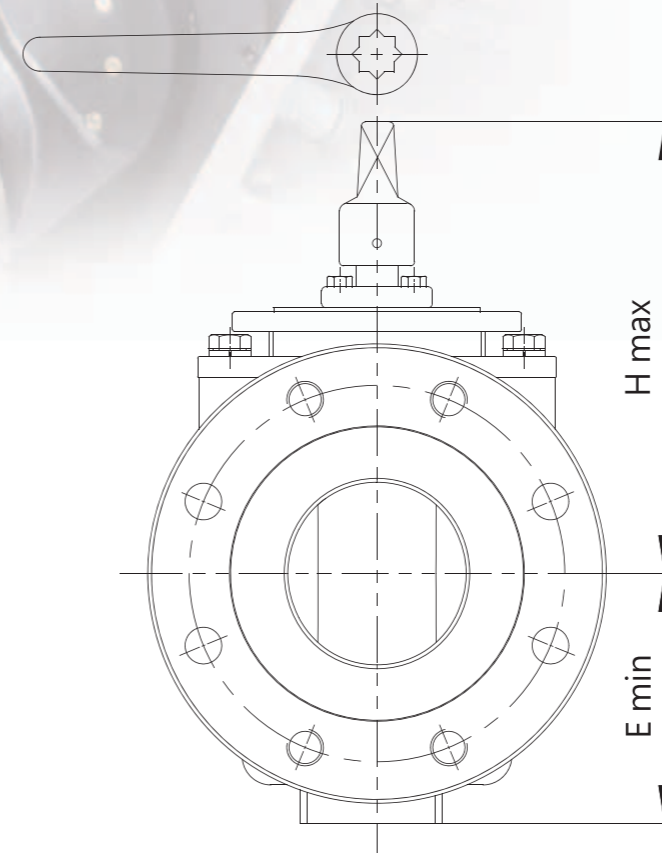

Handwheel 手輪型 DN 400~1000mm

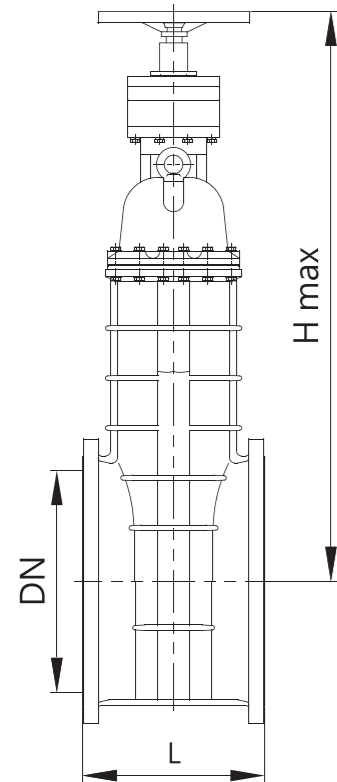

尺寸表/單位 mm

DIM. SIZE	DN	L	H
			max
400	400	406	1500
450	450	432	1700
500	500	457	1850
600	600	508	2000
700	700	610	2450
800	800	660	2500
900	900	711	2600
1000	1000	811	2700



尺寸表/單位 mm

DIM. SIZE	DN	L	H	E
			max	min
50	50	178	150	50
80	80	203	200	100
100	100	229	300	120
125	125	229	350	120
150	150	267	400	150
200	200	292	450	150

# ECCENTRIC PLUG VALVES 偏心式柱塞閥

Handwheel 手輪型 DN 50~800 mm

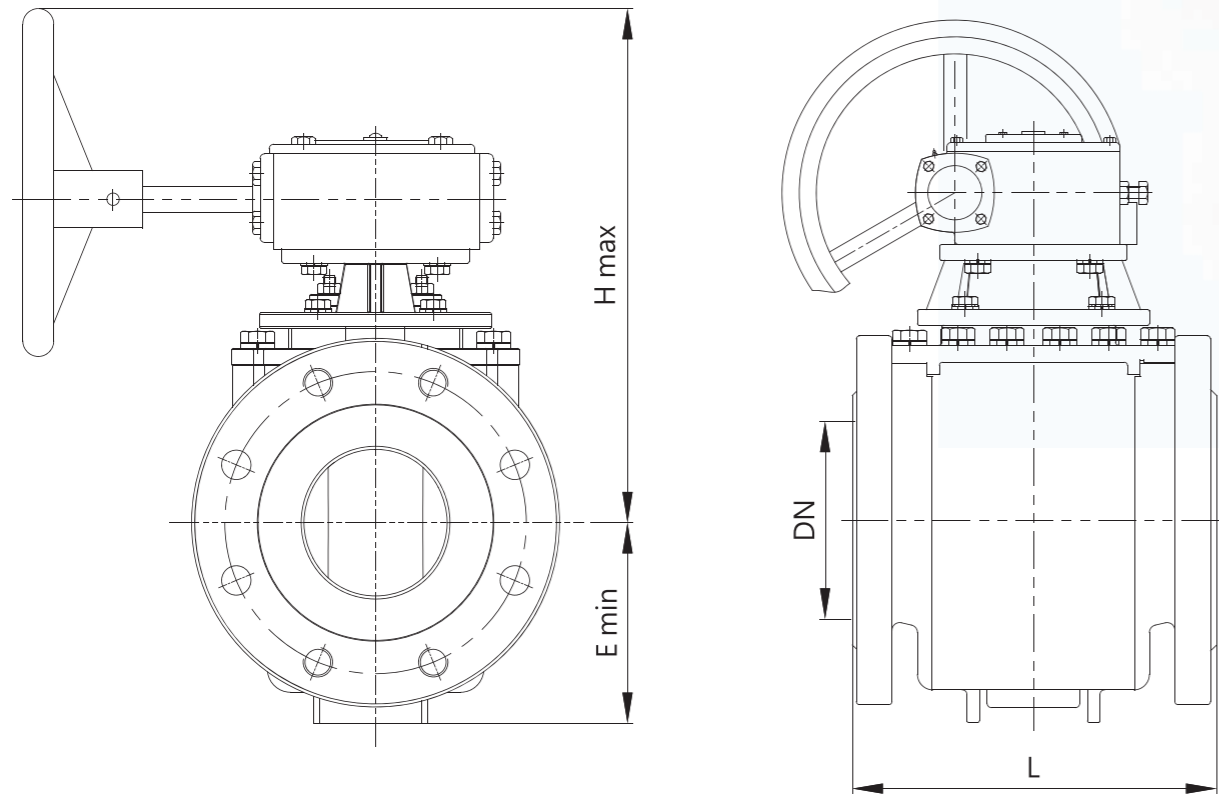

# SLANT TYPE CHECK VALVES 斜盤式逆止閥

DN 150~2000 mm

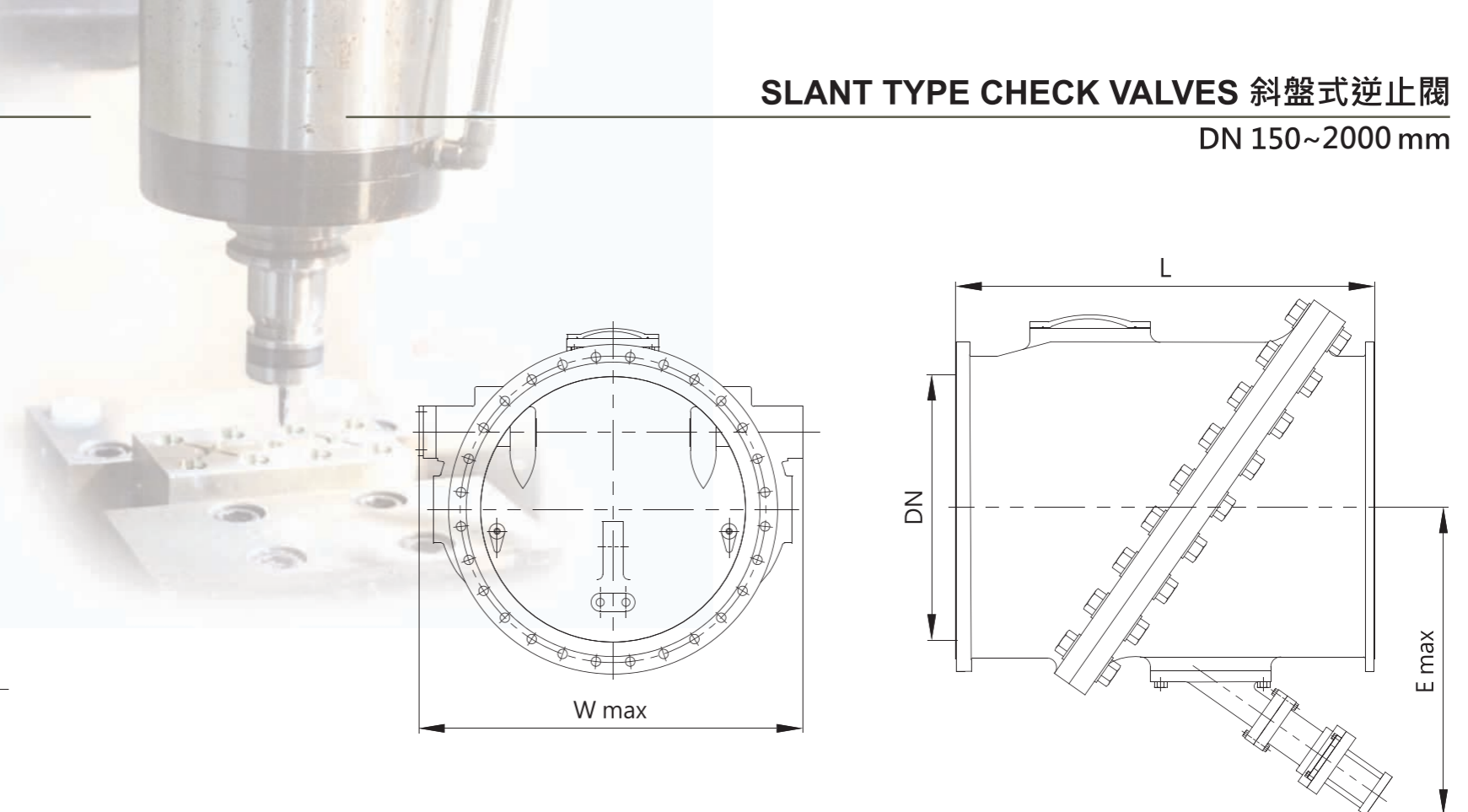

尺寸表/單位 mm

DIM. SIZE	DN	L	E		H
			min	max	
50	50	178	50	300	
80	80	203	100	400	
100	100	229	120	500	
125	125	229	120	550	
150	150	267	150	600	
200	200	292	150	650	
250	250	330	150	750	
300	300	356	200	800	
350	350	406	200	1300	
400	400	406	200	1300	
450	450	620	200	1450	
500	500	620	250	1500	
600	600	700	300	1550	
700	700	800	350	1600	
800	800	1050	400	1600	



尺寸表/單位 mm

DIM. SIZE	DN	L	E		W
			max	max	
150	150	382	400	450	
200	200	495	450	500	
250	250	622	500	650	
300	300	610	550	700	
350	350	762	600	800	
400	400	762	650	900	
450	450	838	700	950	
500	500	813	750	1100	
600	600	965	800	1300	
700	700	1321	900	1500	
800	800	1390	990	1700	
900	900	1511	1050	1900	
1000	1000	1588	1300	2000	
1100	1100	1588	1300	2100	
1200	1200	1651	1300	2300	
1350	1350	1981	1700	2300	
1500	1500	2210	2000	2500	
1800	1800	2590	2100	3200	
2000	2000	3050	2200	3300	

**NOZZLE TYPE CHECK VALVES 單瓣環狀噴流逆止閥**

DN 75~300 mm

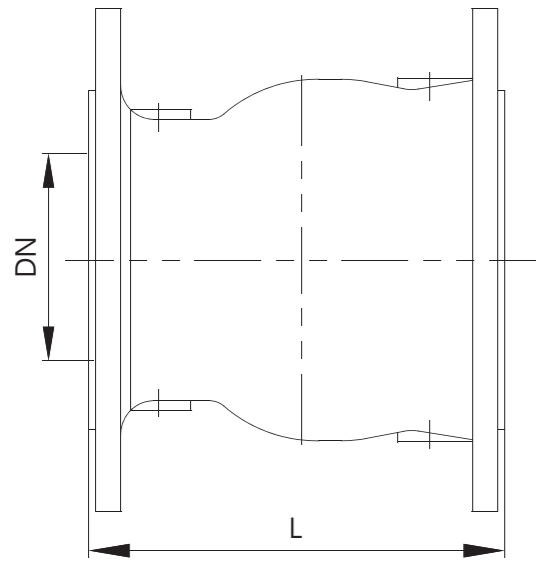

尺寸表/單位 mm

DIM. SIZE	DN	L
75	75	150
100	100	200
150	150	300
200	200	400
250	250	500
300	300	550

**SWING TYPE CHECK VALVE WITH AIR CUSHIONED 空氣緩衝式逆止閥**

DN 75~1050 mm

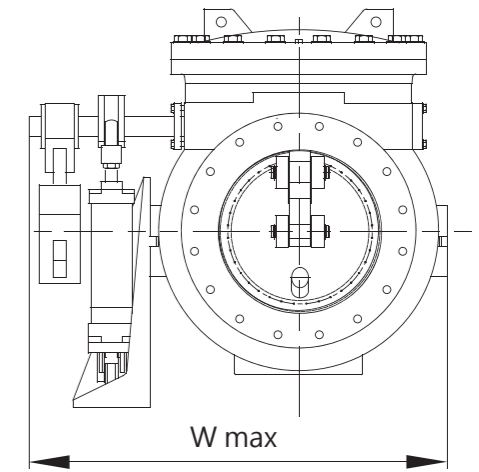
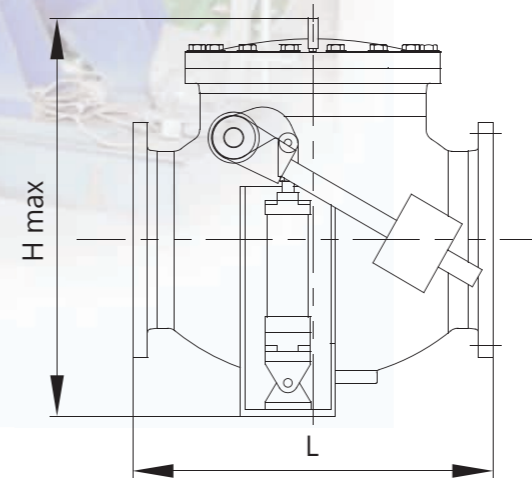

DN 400~1000 mm

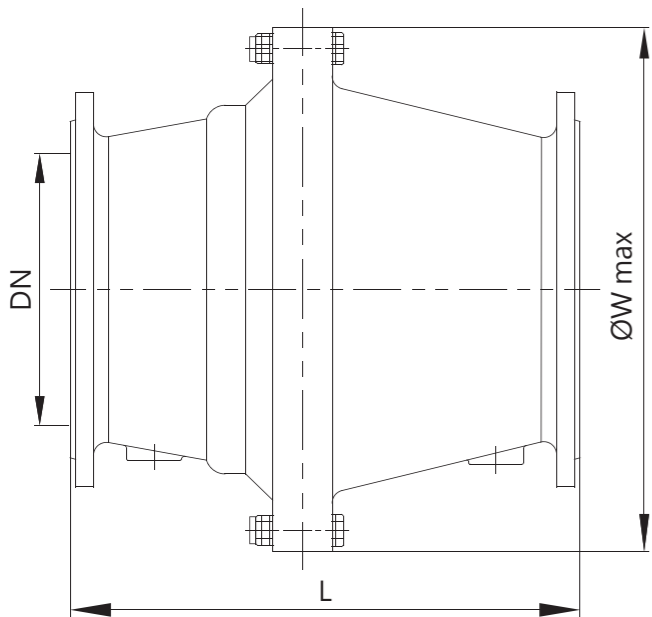

尺寸表/單位 mm

DIM. SIZE	DN	L	ØW max
400	400	680	800
500	500	850	950
600	600	1020	1100
700	700	1190	1250
800	800	1360	1400
900	900	1530	1600
1000	1000	1700	1750



尺寸表/單位 mm

DIM. SIZE	DN	L	H max	W max
75	75	241	585	400
100	100	292	585	450
125	125	356	600	510
150	150	356	600	510
200	200	495	725	650
250	250	622	740	760
300	300	699	860	850
350	350	787	945	1050
400	400	914	1020	1200
450	450	1016	1145	1300
500	500	1016	1250	1330
600	600	1219	1350	1490
750	750	1422	1500	1630
900	900	1600	1760	2500
1050	1050	1778	2300	2800

# 橡膠閥瓣式逆止閥 RUBBER FLAPPER SWING CHECK VALVES

DN 50~900 mm

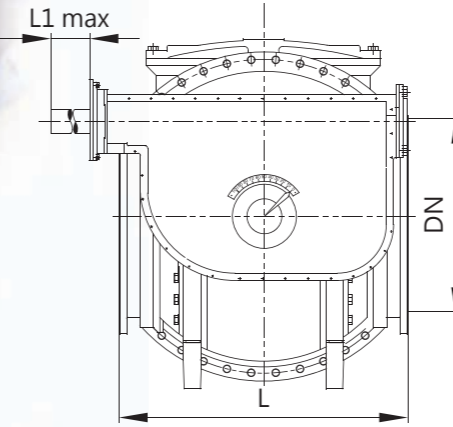
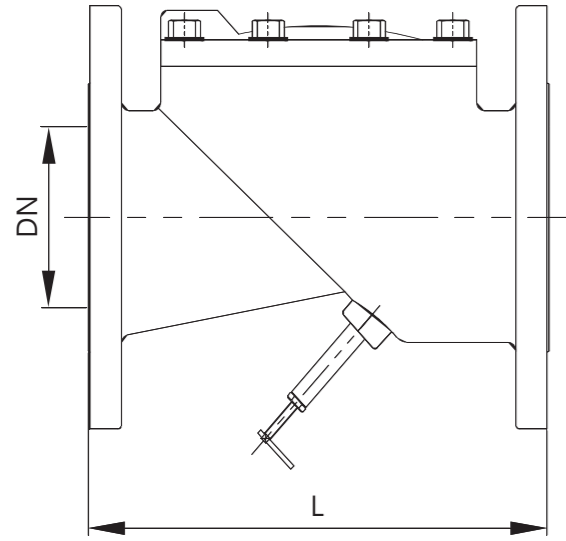

尺寸表/單位 mm

DIM.	SIZE	50	75	100	150	200	250	300	350	400	450	500	600	700	800	900
DN		50	75	100	150	200	250	300	350	400	450	500	600	700	800	900
L		203	241	292	356	495	622	698	787	914	1016	1016	1219	1448	1524	1750

# 雙瓣式逆止閥 DUAL PLATE TYPE CHECK VALVES

DN 50~1000 mm

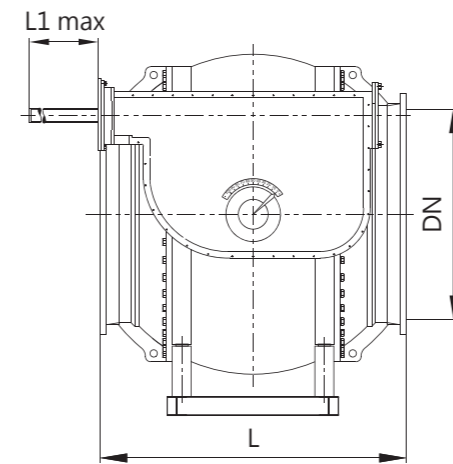
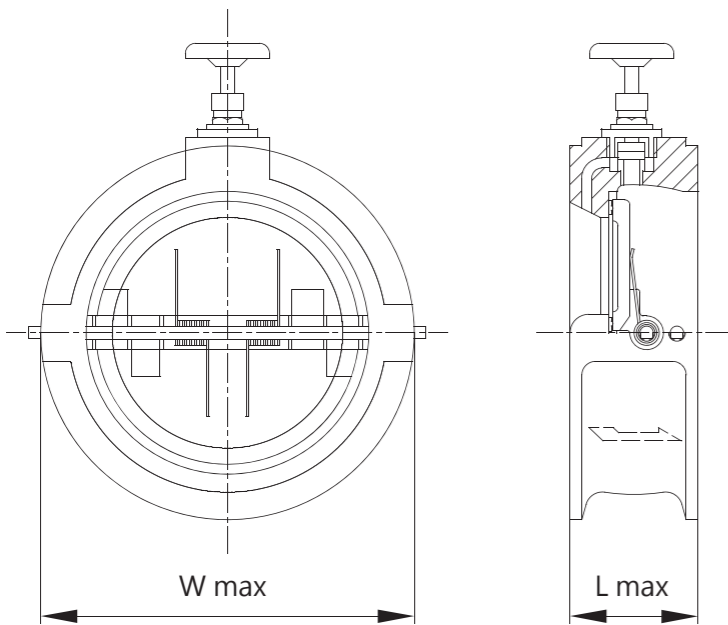

尺寸表/單位 mm

DIM.	SIZE	50	75	100	150	200	250	300	350	400	450	500	600	700	800	900	1000
DN		50	75	100	150	200	250	300	350	400	450	500	600	700	800	900	1000
W max		120	160	190	250	300	350	350	470	530	600	650	750	850	970	1080	1180
L max		65	80	80	95	100	120	120	200	210	230	250	250	350	380	380	430

# BALL TYPE CONTROL VALVES 球型控制閥

DN 300~600 mm

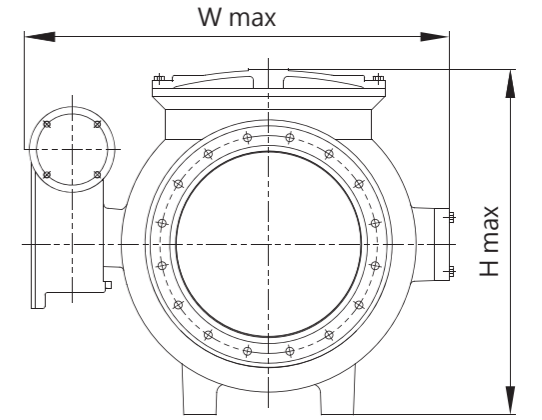

尺寸表/單位 mm

DIM.	DN	L	L1 max	H max	W max
SIZE	300	532	550	700	1000
	400	685	700	850	1200
	500	812	850	1550	1950
	600	939	1000	1800	2150

DN 700~2000 mm

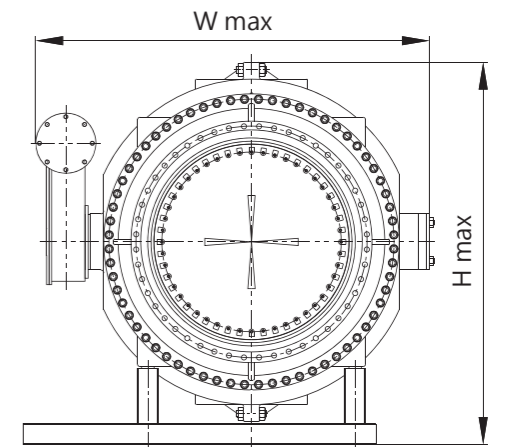

尺寸表/單位 mm

DIM.	DN	L	L1 max	H max	W max
SIZE	700	1150	1300	2150	2600
	800	1300	1300	2300	2650
	900	1422	1350	2400	2850
	1000	1524	1450	2550	3000
	1200	1840	1500	2750	3150
	1350	2072	1650	3000	3200
	1500	2300	1750	3100	3300
	1800	2710	2000	3650	3500
	2000	2990	2050	3800	3900

# HYDRAULIC CONTROL VALVES 水力控制閥

DIAPHRAGM TYPE 隔膜型 DN 75~800 mm

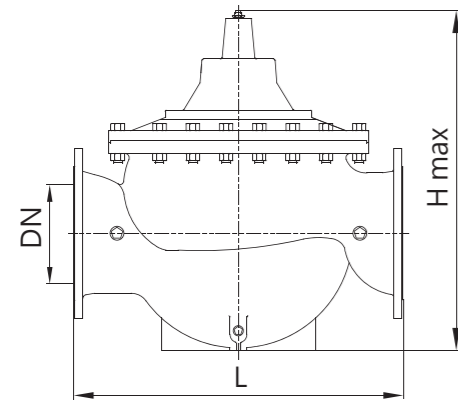

尺寸表/單位 mm

DIM. SIZE	DN	L	H
			max
75	75	285	470
100	100	360	560
150	150	455	700
200	200	585	880
250	250	790	1050
300	300	900	1200
350	350	864	1300
400	400	962	1350
500	500	1076	1650
600	600	1232	1880
700	700	1750	2150
800	800	1750	2150

# SLEEVE TYPE CONTROL VALVES 多/單噴孔錐型套筒控制閥

DN 100~2600 mm

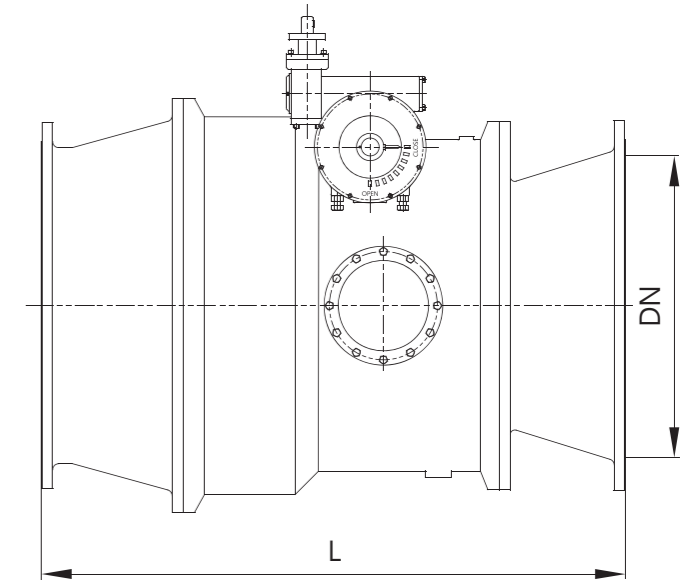
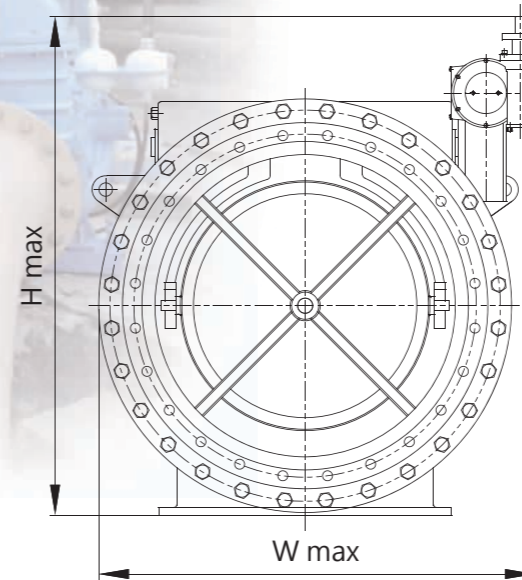

# PISTON TYPE 汽缸型 DN 400~1200 mm

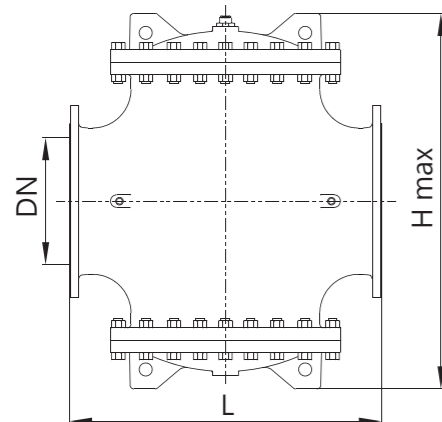

尺寸表/單位 mm

DIM. SIZE	DN	L	H
			max
400	400	962	1180
600	600	1232	1480
700	700	1750	1900
800	800	1750	1900
900	900	2250	2400
1000	1000	2250	2400
1200	1200	2750	2900

尺寸表/單位 mm

DIM. SIZE	DN	L	W	H
			max	max
100	100	645	550	1000
150	150	645	600	1000
200	200	645	650	1350
250	250	645	750	1800
300	300	645	800	1950
350	350	645	850	2050
400	400	1100	1000	2050
500	500	1250	1150	2050
600	600	1250	1250	2050
700	700	2000	1350	2050
800	800	2000	1450	2050
900	900	2000	1650	2350
1000	1000	2000	1750	2450
1200	1200	2500	1950	2600
1350	1350	2500	2100	2650
1500	1500	3200	2300	2800
1800	1800	3200	2550	2800
2000	2000	3300	2850	3100
2200	2200	3300	3250	3650
2400	2400	3800	3550	3950
2600	2600	3800	3800	4200

# SINGLE EXTENSION JOINTS 單拉桿伸縮接頭

DN 75~2600 mm

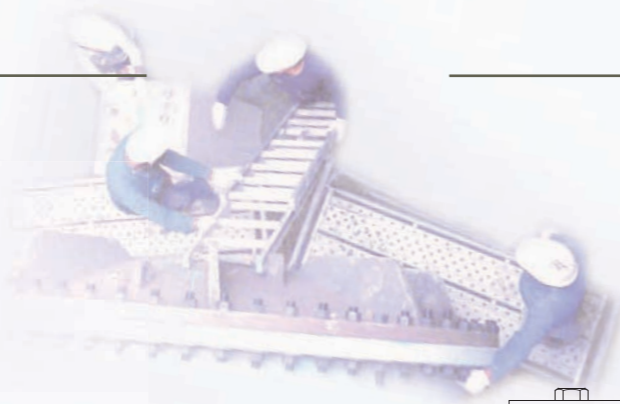
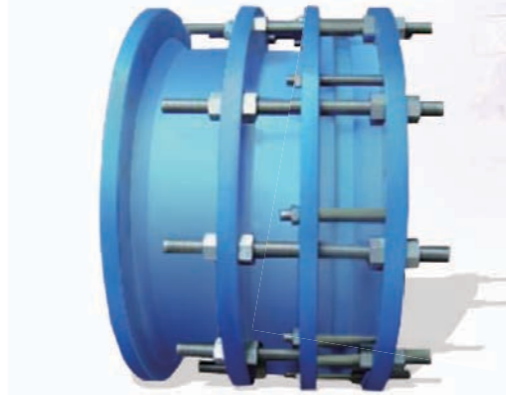
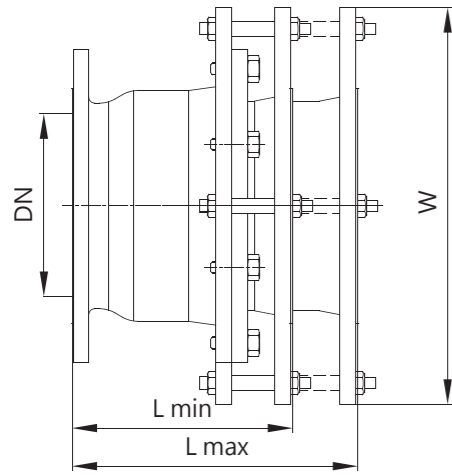

尺寸表/單位 mm

DIM. \ SIZE	75	100	150	200	250	300	350	400	450	500	600	700	800	900	1000	1100	1200	1350	1500	1600	1650	1800	2000	2100	2200	2400	2600
DN	75	100	150	200	250	300	350	400	450	500	600	700	800	900	1000	1100	1200	1350	1500	1600	1650	1800	2000	2100	2200	2400	2600
L	min	270	285	290	295	300	320	330	330	340	350	360	370	370	380	385	385	430	430	435	535	635	735	735	735	835	835
	max	310	325	330	335	340	360	370	380	390	400	410	420	430	440	445	445	490	490	495	595	695	795	795	795	895	895
w	299	326	378	430	521	569	648	700	787	833	944	1063	1169	1291	1400	1505	1615	1790	1955	2077	2120	2270	2515	2595	2725	2930	3155

# DOUBLE EXTENSION JOINTS 雙拉桿伸縮接頭

DN 75~2600 mm

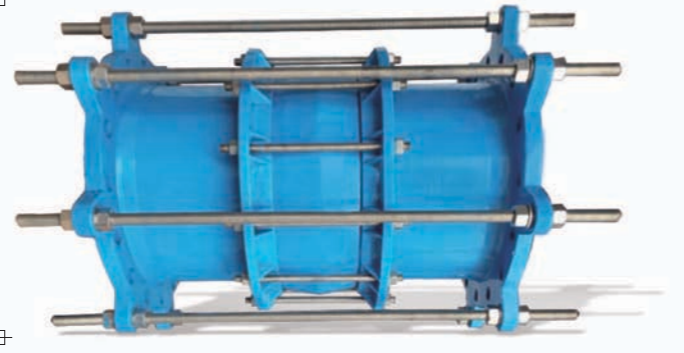
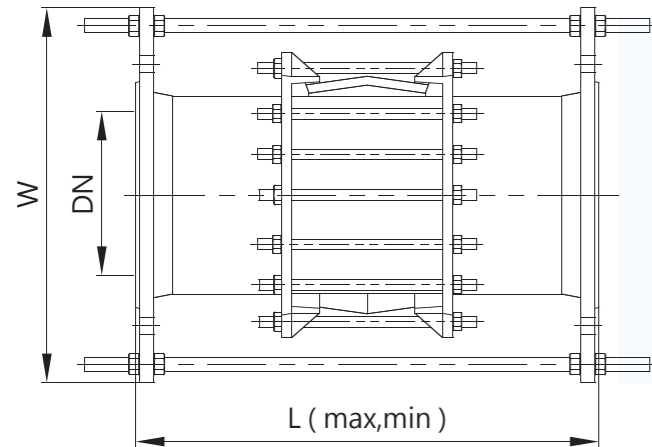

尺寸表/單位 mm

DIM. \ SIZE	75	100	150	200	250	300	350	400	450	500	600	700	800	900	1000	1100	1200	1350	1500	1600	1650	1800	2000	2100	2200	2400	2600
DN	75	100	150	200	250	300	350	400	450	500	600	700	800	900	1000	1100	1200	1350	1500	1600	1650	1800	2000	2100	2200	2400	2600
w	299	326	378	430	515	569	648	700	787	841	945	1063	1169	1291	1397	1501	1605	1777	1935	2057	2107	2257	2483	2588	2708	2918	3140
L	min	500	500	600	600	600	700	700	700	700	700	800	800	800	800	800	900	900	1000	1200	1300	1400	1500	1500	1500	1600	1600
	max	570	580	710	720	730	860	870	875	880	890	950	950	950	950	950	1070	1070	1190	1390	1490	1650	1750	1750	1750	1850	1850

# CROSS EXTENSION JOINTS WITH STRAINER 十字濾管

DN 50~2000 mm

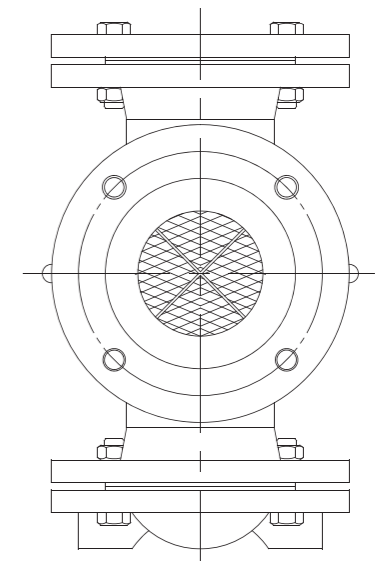
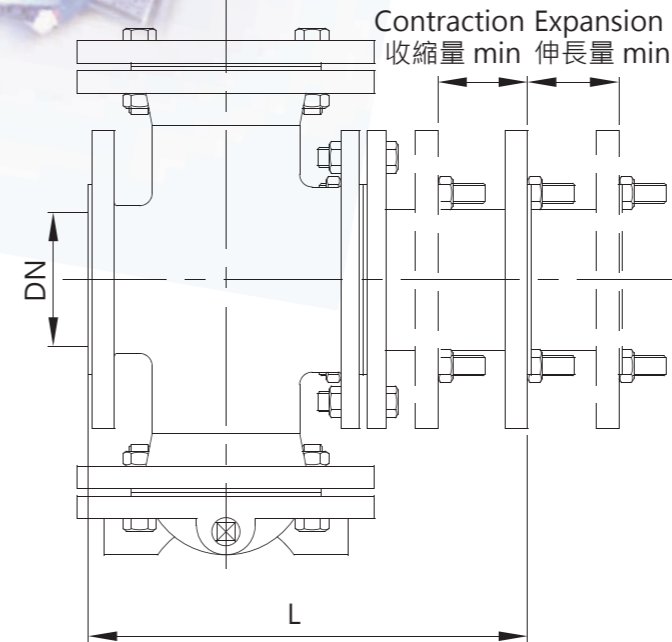

尺寸表/單位 mm

DIM. \ SIZE	DN	L	Contraction 收縮量 min	Expansion 伸長量 min
50	50	260	20	20
75	75	280	20	20
100	100	300	20	20
150	150	425	20	20
200	200	500	40	40
250	250	650	80	80
300	300	750	125	125
350	350	875	150	150
400	400	1000	160	160
450	450	1125	175	175
500	500	1250	175	175
600	600	1500	175	175
700	700	1750	175	175
750	750	1750	175	175
800	800	2000	175	175
900	900	2250	175	175
1000	1000	2500	175	175
1200	1200	2500	175	175
1350	1350	2500	175	175
1500	1500	2500	175	175
1800	1800	2500	175	175
2000	2000	2500	200	200





# BALL FLEXIBLE EXPANSION JOINT 球型可撓管

DN 75~1500 mm

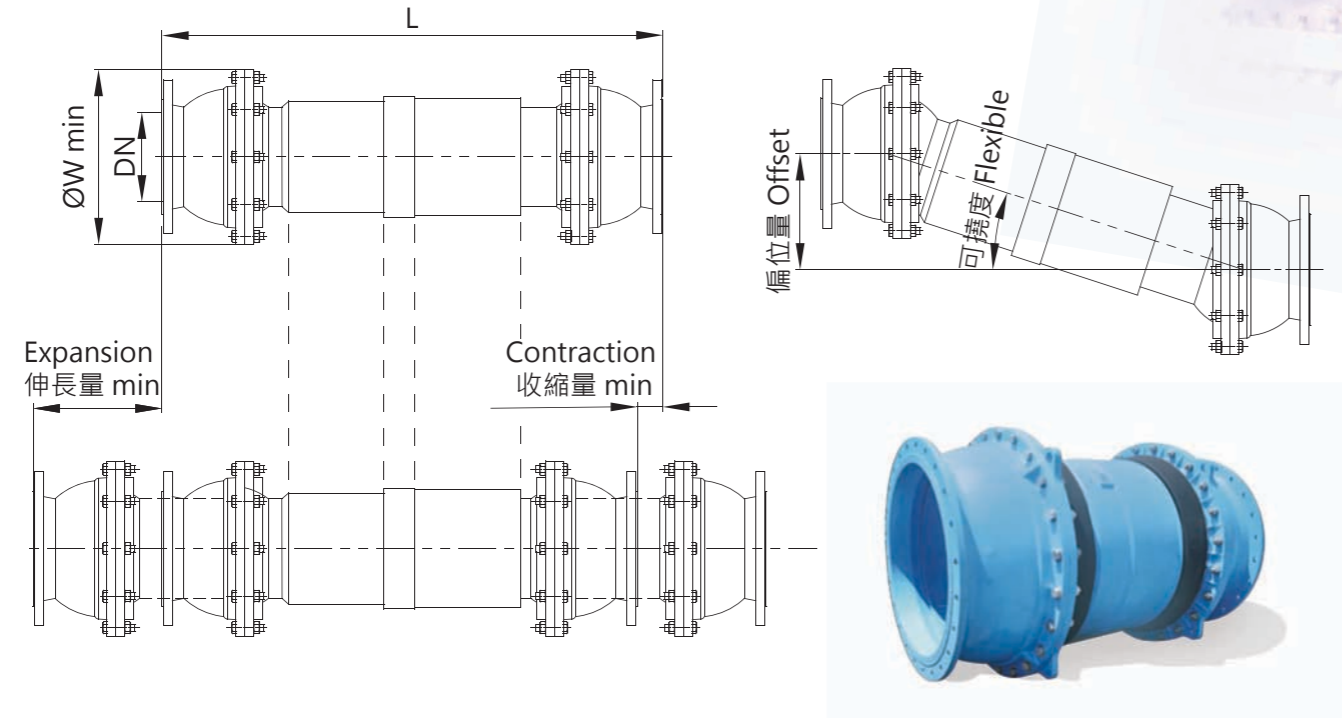

尺寸表/單位 mm

DIM. SIZE	DN	ØW min	偏位量 Offset 100 mm		偏位量 Offset 200 mm		偏位量 Offset 300 mm		可撓度 Flexible			
			Expansion 伸長量 min	Contraction 收縮量 min	Expansion 伸長量 min	Contraction 收縮量 min	Expansion 伸長量 min	Contraction 收縮量 min				
75	75	200	730	70	30	950	150	50	1200	200	100	15
100	100	250	800	70	30	1020	150	50	1270	200	100	15
150	150	300	830	70	30	1060	150	50	1310	200	100	15
200	200	350	890	70	30	1110	150	50	1360	200	100	15
250	250	450	940	70	30	1150	150	50	1400	200	100	15
300	300	500	1030	70	30	1280	150	50	1530	200	100	15
350	350	500				1360	150	50	1620	200	100	15
400	400	600				1400	150	50	1650	200	100	15
450	450	750				1460	150	50	1710	200	100	15
500	500	750				1520	150	50	1780	200	100	15
600	600	850				1570	150	50	1830	200	100	1□
700	700	1000				1980	150	50	2240	200	100	1□
800	800	1150				2050	150	50	2310	200	100	1□
900	900	1250				2125	150	50	2385	200	100	1□
1000	1000	1400				2185	150	50	2445	200	100	1□
1100	1100	1400				2300	150	50	2560	200	100	1□
1200	1200	1600				2400	150	50	2660	200	100	1□
1350	1350	1750				2500	150	50	2760	200	100	1□
1500	1500	1950				2750	150	50	3010	200	100	1□

# STEEL EXPANSION JOINT 鋼製可撓管

Short Pattern 短體型 DN 300~2600 mm

尺寸表/單位 mm

DIM. SIZE	DN	偏位量 Offset 50 mm			偏位量 Offset 100 mm			可撓度 Flexible		
		L	Expansion 伸長量 min	Contraction 收縮量 min	L	Expansion 伸長量 min	Contraction 收縮量 min			
300	300	850	10	120	100	1270	10	120	100	□
400	400	850	10	120	100	1270	10	120	100	□
500	500	950	10	120	100	1370	10	120	100	□
600	600	950	10	120	100	1370	10	120	100	□
700	700	970	10	120	100	1390	10	120	100	□
800	800	990	10	120	100	1410	10	120	100	□
900	900	1010	10	120	100	1430	10	120	100	□
1000	1000	1070	15	130	100	1520	15	130	100	5
1100	1100	1100	15	130	100	1550	15	130	100	5
1200	1200	1100	15	130	100	1550	15	130	100	5
1350	1350	1120	15	130	100	1570	15	130	100	5
1500	1500	1160	15	130	100	1610	15	130	100	5
1650	1650	1160	15	130	100	1620	15	130	100	□
1800	1800	1220	15	140	100	1700	15	140	100	□
2000	2000	1260	□	140	100	1740	□	140	100	□
2200	2200	1340	□	140	100	1820	□	140	100	□
2400	2400	1420	□	140	100	1920	□	140	100	□
2600	2600	1490	□	140	100	1960	□	140	100	□

Long Pattern 長體型 DN 700~2600 mm

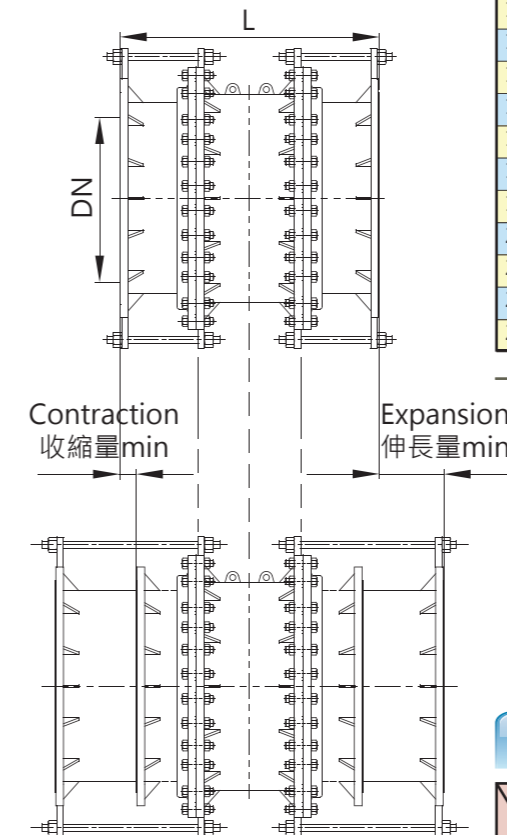

尺寸表/單位 mm

DIM. SIZE	DN	偏位量 Offset 100 mm			偏位量 Offset 200 mm			可撓度 Flexible		
		L	Expansion 伸長量 min	Contraction 收縮量 min	L	Expansion 伸長量 min	Contraction 收縮量 min			
700	700	2300	□	300	130	3100	□	300	130	□
800	800	2400	□	300	130	3200	□	300	130	□
900	900	2500	□	300	130	3300	□	300	130	□
1000	1000	2600	□	300	130	3500	□	300	130	5
1100	1100	2700	□	300	130	3600	□	300	130	5
1200	1200	2800	□	320	130	3700	□	320	130	5
1350	1350	2800	□	320	130	3700	□	320	130	5
1500	1500	3100	□	340	130	4000	□	340	130	5
1650	1650	3100	□	340	130	4100	□	340	130	□
1800	1800	3100	□	360	130	4100	□	360	130	□
2000	2000	3300	□	360	130	4300	□	360	130	□
2200	2200	3300	□	360	130	4300	□	360	130	□
2400	2400	3600	□	360	130	4600	□	360	130	□
2600	2600	3750	□	360	130	4750	□	360	130	□

# BALL FLEXIBLE EXPANSION JOINT 球型可撓管

DN 75~1500 mm

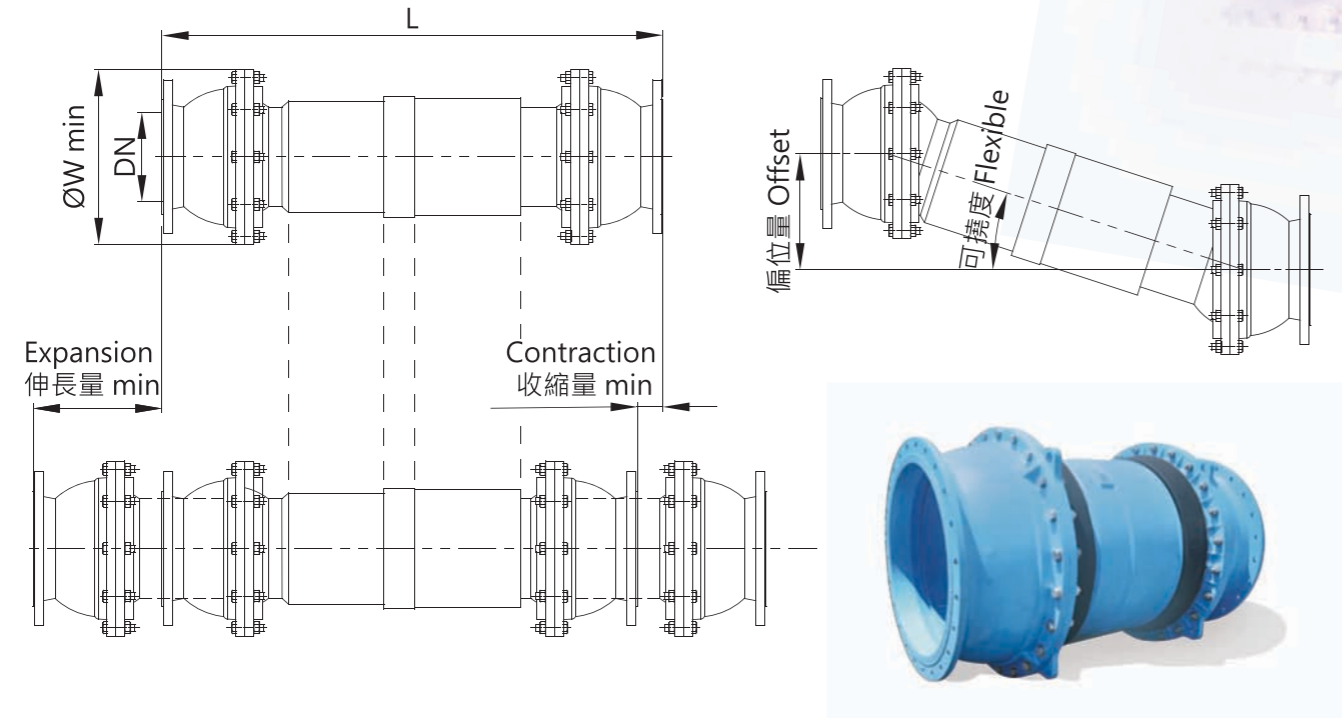

尺寸表/單位 mm

DIM. SIZE	DN	ØW min	偏位量 Offset 100 mm			偏位量 Offset 200 mm			偏位量 Offset 300 mm			可撓度 Flexible min
			L±20	Expansion 伸長量 min	Contraction 收縮量 min	L±20	Expansion 伸長量 min	Contraction 收縮量 min	L±20	Expansion 伸長量 min	Contraction 收縮量 min	
75	75	200	730	70	30	950	150	50	1200	200	100	15°
100	100	250	800	70	30	1020	150	50	1270	200	100	15°
150	150	300	830	70	30	1060	150	50	1310	200	100	15°
200	200	350	890	70	30	1110	150	50	1360	200	100	15°
250	250	450	940	70	30	1150	150	50	1400	200	100	15°
300	300	500	1030	70	30	1280	150	50	1530	200	100	15°
350	350	500				1360	150	50	1620	200	100	15°
400	400	600				1400	150	50	1650	200	100	15°
450	450	750				1460	150	50	1710	200	100	15°
500	500	750				1520	150	50	1780	200	100	15°
600	600	850				1570	150	50	1830	200	100	14°
700	700	1000				1980	150	50	2240	200	100	13°
800	800	1150				2050	150	50	2310	200	100	13°
900	900	1250				2125	150	50	2385	200	100	13°
1000	1000	1400				2185	150	50	2445	200	100	13°
1100	1100	1400				2300	150	50	2560	200	100	13°
1200	1200	1600				2400	150	50	2660	200	100	13°
1350	1350	1750				2500	150	50	2760	200	100	12°
1500	1500	1950				2750	150	50	3010	200	100	12°

# STEEL EXPANSION JOINT 鋼製可撓管

Short Pattern 短體型 DN 300~2600 mm

尺寸表/單位 mm

DIM. SIZE	DN	偏位量 Offset 50 mm			偏位量 Offset 100 mm			可撓度 Flexible min
		L	Expansion 伸長量 min	Contraction 收縮量 min	L	Expansion 伸長量 min	Contraction 收縮量 min	
300	300	850±10	120	100	1270±10	120	100	6°
400	400	850±10	120	100	1270±10	120	100	6°
500	500	950±10	120	100	1370±10	120	100	6°
600	600	950±10	120	100	1370±10	120	100	6°
700	700	970±10	120	100	1390±10	120	100	6°
800	800	990±10	120	100	1410±10	120	100	6°
900	900	1010±10	120	100	1430±10	120	100	6°
1000	1000	1070±15	130	100	1520±15	130	100	5°
1100	1100	1100±15	130	100	1550±15	130	100	5°
1200	1200	1100±15	130	100	1550±15	130	100	5°
1350	1350	1120±15	130	100	1570±15	130	100	5°
1500	1500	1160±15	130	100	1610±15	130	100	5°
1650	1650	1160±15	130	100	1620±15	130	100	4°
1800	1800	1220±15	140	100	1700±15	140	100	4°
2000	2000	1260±20	140	100	1740±20	140	100	4°
2200	2200	1340±20	140	100	1820±20	140	100	4°
2400	2400	1420±20	140	100	1920±20	140	100	4°
2600	2600	1490±20	140	100	1960±20	140	100	4°

Long Pattern 長體型 DN 700~2600 mm

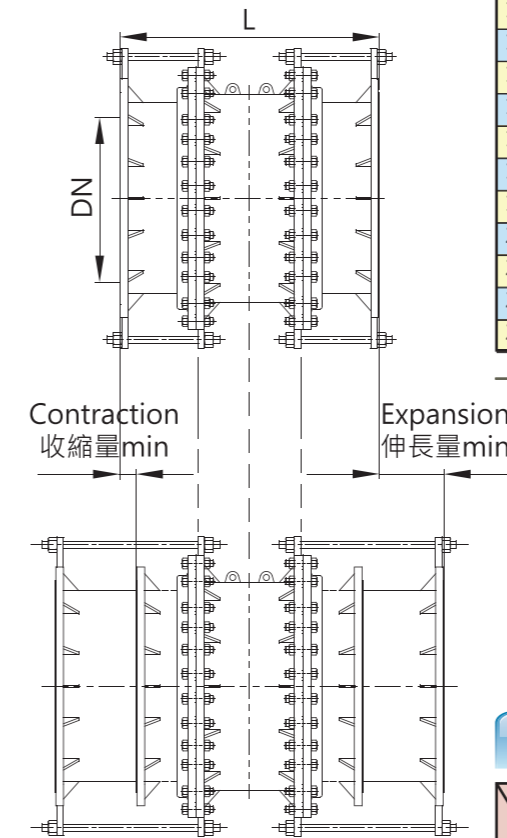

尺寸表/單位 mm

DIM. SIZE	DN	偏位量 Offset 100 mm			偏位量 Offset 200 mm			可撓度 Flexible min
		L	Expansion 伸長量 min	Contraction 收縮量 min	L	Expansion 伸長量 min	Contraction 收縮量 min	
700	700	2300±20	300	130	3100±25	300	130	6°
800	800	2400±20	300	130	3200±25	300	130	6°
900	900	2500±20	300	130	3300±25	300	130	6°
1000	1000	2600±20	300	130	3500±25	300	130	5°
1100	1100	2700±20	300	130	3600±25	300	130	5°
1200	1200	2800±20	320	130	3700±25	320	130	5°
1350	1350	2800±20	320	130	3700±25	320	130	5°
1500	1500	3100±25	340	130	4000±25	340	130	5°
1650	1650	3100±25	340	130	4100±25	340	130	4°
1800	1800	3100±25	360	130	4100±25	360	130	4°
2000	2000	3300±25	360	130	4300±25	360	130	4°
2200	2200	3300±25	360	130	4300±25	360	130	4°
2400	2400	3600±25	360	130	4600±25	360	130	4°
2600	2600	3750±25	360	130	4750±25	360	130	4°

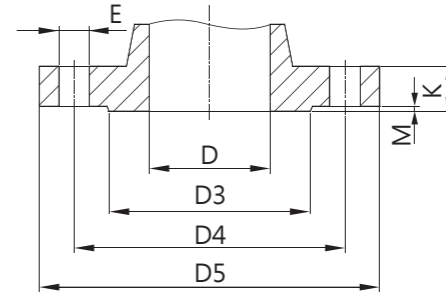
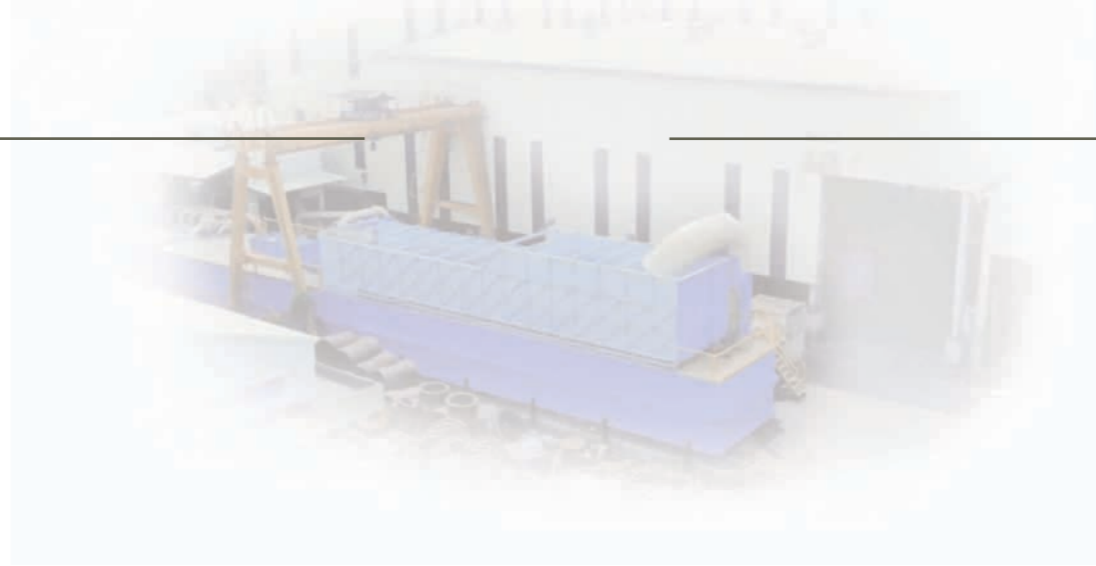
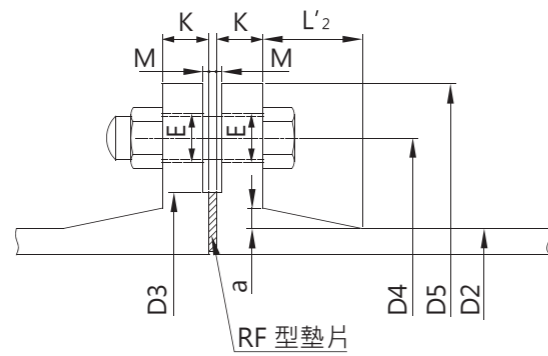

標稱 口徑	外徑	7.5K										10K													
		各部尺度										螺 栓 數 量	凸 緣 質 量 (KG)	各部尺度										螺 栓 數 量	凸 緣 質 量 (KG)
		D3	D4	D5	K	M	E	a	L'2	D3	D4			D5	K	M	E	a	L'2						
75	93.0	125	168	211	21	3	19	5	26	4	3.77	126	150	185	18	2	19	5	24	8	2.28				
100	118.0	152	195	238	21	3	19	5	26	4	4.55	151	175	210	18	2	19	5	24	8	2.75				
150	169.0	204	247	290	22	3	19	5	26	6	6.22	212	240	280	22	2	23	5	24	8	5.59				
200	220.0	256	299	342	23	3	19	5	26	8	8.06	262	290	330	22	2	23	5	29	12	6.75				
250	271.6	308	360	410	24	3	23	5	26	8	11.5	324	355	400	24	2	25	6	30	12	10.7				
300	322.8	362	414	464	25	3	23	5	32	10	14.2	368	400	445	24	3	25	7	33	16	11.4				
350	374.0	414	472	530	26	3	25	5	32	10	18.8	413	445	490	26	3	25	7	36	16	13.4				
400	425.6	466	524	582	27	3	25	5	32	12	21.8	475	510	560	28	3	27	8	39	16	19.4				
450	476.8	518	585	652	28	3	27	5	32	12	28.3	530	565	620	30	3	27	9	42	20	24.7				
500	528.0	572	639	706	29	4	27	6	32	12	32.0	585	620	675	30	3	27	9	45	20	28.3				
600	630.8	676	743	810	30	4	27	6	32	16	38.9	690	730	795	32	3	33	10	51	24	39.0				
700	733.0	780	854	928	31	4	33	6	32	16	49.9	800	840	905	34	3	33	12	57	24	52.1				
800	836.0	886	960	1034	32	4	33	14	68	20	66.1	905	950	1020	36	3	33	13	63	28	67.7				
900	939.0	990	1073	1156	33	4	33	15	77	20	85.3	1005	1050	1120	38	3	33	14	71	28	80.3				
1000	1041.0	1096	1179	1262	34	4	33	17	84	24	101	1110	1160	1235	40	3	39	16	77	28	100				
1100	1144.0	1200	1283	1366	36	4	33	18	90	24	120	1220	1270	1345	42	3	39	17	83	28	122				
1200	1246.0	1304	1387	1470	38	4	33	19	96	28	140	1325	1380	1465	44	3	39	18	89	32	152				
1350	1400.0	1462	1552	1642	40	4	39	21	110	28	181	1480	1540	1630	48	3	45	20	100	36	194				
1500	1554.0	1620	1710	1800	42	5	39	24	115	32	216	1635	1700	1795	50	3	45	22	110	40	239				
1600	1650.0	1760	1820	1915	47	5	39	24	120	36	275	1760	1820	1915	55	5	49	22	110	40	295				
1650	1701.0	1810	1870	1965	48	5	39	24	120	40	286	1810	1870	1965	56	5	49	22	110	40	308				
1800	1848.0	1960	2020	2115	49	5	39	24	120	44	318	1960	2020	2115	60	5	49	22	110	44	358				
2000	2061.0	2170	2230	2325	51	5	46	25	125	48	360	2170	2230	2325	65	5	49	22	110	48	421				
2100	2164.0	2270	2335	2430	52	5	46	25	125	48	386	2270	2335	2430	68	5	49	22	110	52	461				
2200	2280.0	2370	2440	2550	54	6	46	26	130	52	424	2370	2440	2550	71	6	56	22	110	52	494				
2400	2458.0	2570	2650	2760	56	6	46	28	140	56	538	2570	2650	2760	76	6	56	24	120	56	651				
2600	2684.0	2780	2850	2960	58	6	52	28	140	56	549	2780	2850	2960	81	6	56	24	120	60	683				

標稱 口徑	D	150lb							螺 栓 數 量	300lb					螺 栓 數 量
		各部尺度								各部尺度					
		D3	D4	D5	K	M	E	D3		D4	D5	K	M	E	
2	50	92	121	150	19	2	19	4	92	127	165	22	2	19	8
2½	65	105	140	180	22	2	19	4	105	149	190	26	2	22	8
3	75	127	152	190	24	2	19	4	127	168	210	29	2	22	8
3½	90	140	178	216	24	2	19	8	140	184	229	30	2	22	8
4	100	157	191	229	24	2	19	8	157	200	254	32	2	22	8
5	125	186	216	254	24	2	23	8	186	235	280	35	2	22	8
6	150	216	241	280	25	2	23	8	216	270	318	37	2	22	12
8	200	270	299	343	29	2	23	8	270	330	381	41	2	29	12
10	250	324	362	406	30	2	26	12	324	387	445	48	2	32	16
12	300	381	432	483	32	2	26	12	381	451	521	51	2	32	16
14	350	413	476	533	35	2	29	12	413	514	584	54	2	35	20
16	400	470	540	597	37	2	29	16	470	572	648	57	2	35	20
18	450	533	578	635	40	2	32	16	533	629	711	60	2	35	24
20	500	584	635	699	43	2	32	20	584	686	775	64	2	35	24
24	600	692	749	813	48	2	35	20	692	813	914	70	2	41	24